

# Installation Instructions

## 4040XP.TANDEM.61.US28



**relcross door controls®**

distributors of **ANSI** grade, **UK** & **CE** marked commercial door hardware

Relcross Ltd, Hambleton Avenue, DEVIZES, Wiltshire, SN10 2RT, UK | T: +44 (0)1380 729600 E: sales@relcross.co.uk W: www.relcross.co.uk  
VAT registration number: GB 771264821 EORI registration number: GB 771264821000

## Installation – 4040XP.TANDEM.61.US28

### Introduction

You have been provided with the following:

**4040XP.TANDEM.61. RH** Extra Heavy Duty Closer - Silver, Top Jamb (Push Side) Mounting w. Regular Duty Arm (Right Hand)

RH (Right Hand) models suit anti-clockwise closing doors (viewed in plan)

and/or

**4040XP.TANDEM.61. LH** Extra Heavy Duty Closer - Silver, Top Jamb (Push Side) Mounting w. Regular Duty Arm (Left Hand)

LH (Left Hand) models suit clockwise closing doors (viewed in plan)

### Components List (Per Door Closer, Per Leaf)

Part #1            4040XP-3071.US28 Closer Mechanism – Non-Handed (2 off)  
                         (Prepared for Top Jamb (Push Side) Mounting)

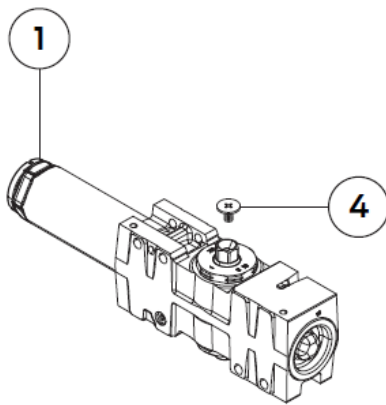

Part #3            4040XP-72MC.US28 Metal Closer Cover – Handed (2 off)  
Lower – Cut top & bottom to accommodate pinion shaft for arm & bush connector  
Upper – Cut bottom only to accommodate bush connector with U slots for fixing

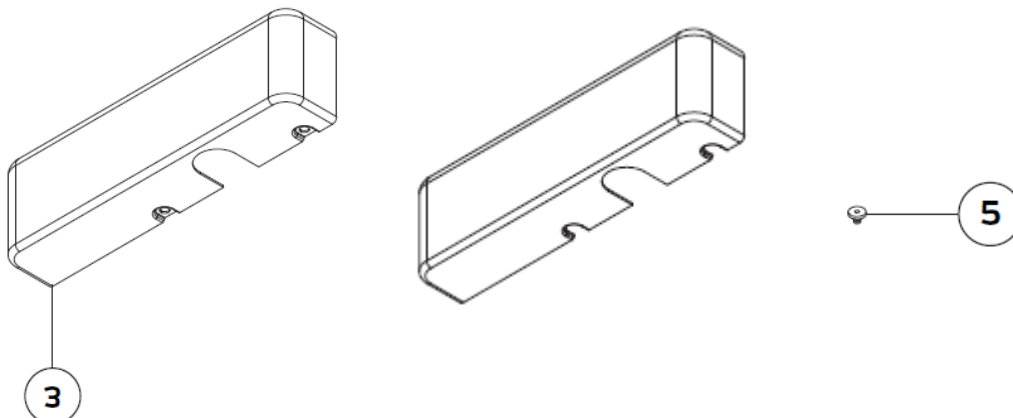

Part #4 4040XP-159 Arm Screw – (1 off - see page 2)

Secures the closer arm to the lower mechanism. Note the mark on the arm and the lower closer mechanism pinion shaft. This is an aid to alignment for correct pre-load. See below (page 7)

Part #5 4040XP-31 Cover Screw – (4 off - see page 2)

Secures the metal covers (2 off per cover) to the upper and lower mechanisms (3/32 Allen key provided). The sequence of assembly is important. The upper cover must be installed first. See below (page 9)

Part #6 4040XP-3077.US28 Regular Duty Door Closer Arm – Non-Handed (1 off)

Fixed to the pinion shaft via the hex hole on the main arm (see also Part #4). The arm shoe (bull nose trim) is fixed to the door. See below (page 7)

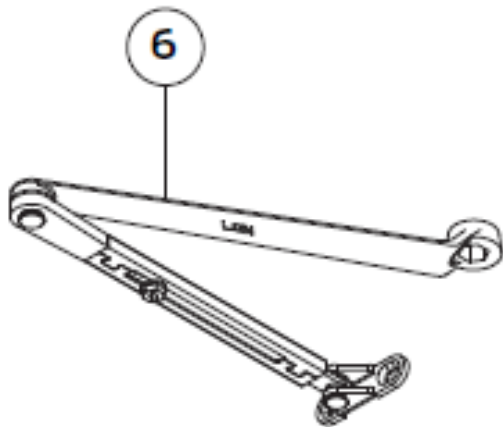

Part #7 4040XP-TANDEM.PLATE.US28 Mounting Plate – Non-Handed (1 off)

Fixed to the top jamb (push side) of the door/frame assembly. Accommodates the closer mechanisms (see Part #1). \*Drilled and tapped for 8 off M6 x 50mm closer mechanism mounting bolts and prepared with 11 off CSK clearance holes for M6 x 16mm machine screws.

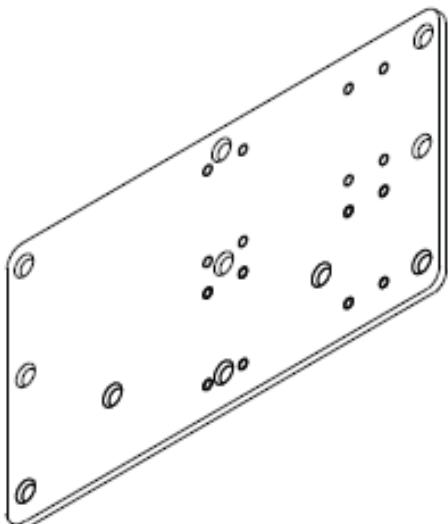

\*All fixings provided – CSK hole pattern may vary from the drawing (dictated by frame detail)

Part #8 4040XP-TANDEM.BUSH Connector – (1 off)

Connects the closer mechanisms at the pinion shaft



We have supplied one complete closer fully assembled (but LESS the closer arm) to show you how the parts fit together. Use this as your guide for assembly.

NB – there is no part #2

The **4040XP.TANDEM.61** Extra Heavy Duty Closer is designed to suit conventional doors <272 kilos. Internal doors widths <1524mm and perimeter door widths <1220mm. For exceptional door widths consult the sales office before proceeding. Maximum hinge open width 127mm. For doors hung on projection (wide throw) hinges consult the sales office before proceeding.

NB - When using offset pivots or swing clear hinges, always locate the closer and shoe from the centre line – i.e., the pivot point.

### Installation – Step One

Establish the hand of the door:

Plan View

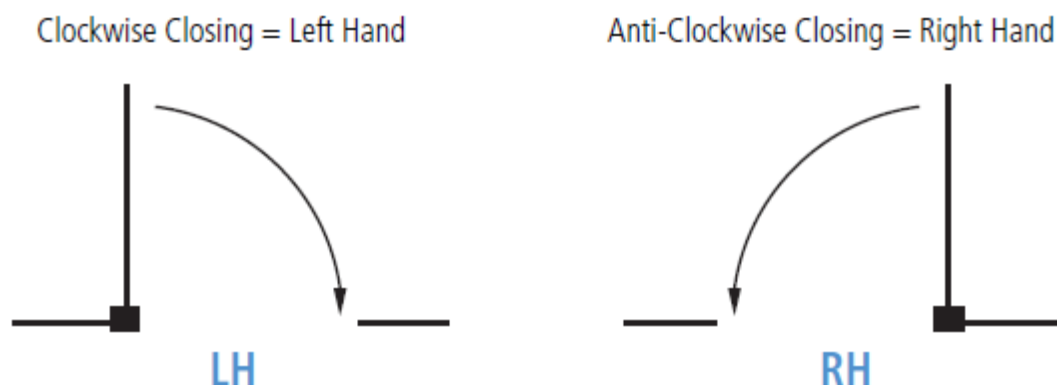

Select the correct handing – clearly marked on each complete box.

## Installation – Step Two

(Maximum Opening Angle 120°)

Mounting the 4040XP-TANDEM.PLATE.US28 – Part #7 to the top jamb (push side):

For **Left Hand Doors** (Right Hand Opposite)

Vertical Mounting Plate Alignment – **Dimension A**. The lower most row of drilled and tapped holes - i.e., those closest to the edge of the plate - must be within 17mm of the underside of the reveal or stop face, as indicated (see below). This will ensure the closer arm passes beneath the underside of the reveal as the door opens.

The mounting plate may be fixed lower if necessary and if the door height is sufficient to allow movement through the door without the closer or closer arm becoming an obstruction. We can prepare the CSK clearance holes accordingly for all scenarios.

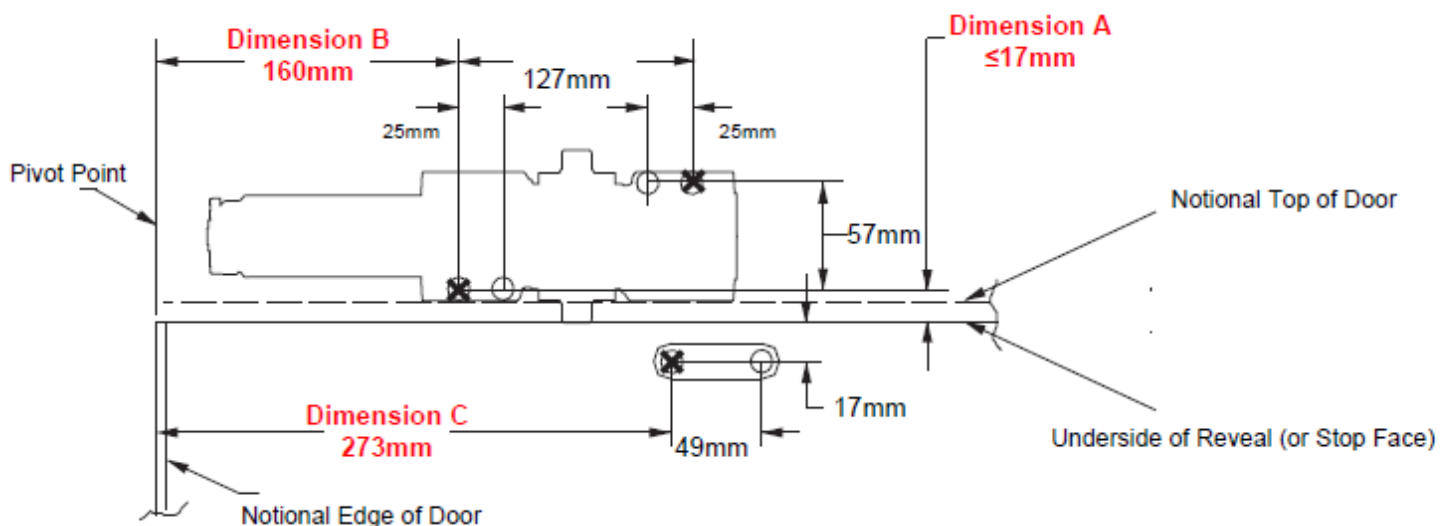

Lateral Mounting Plate Alignment – **Dimension B** aligns with the left hand most set of drilled and tapped holes, as indicated (see above). This dimension is taken from the centre line of the pivot point of the door.

Lateral Arm Shoe Alignment - **Dimension C**. This dimension is taken from the centre line of the pivot point of the door.

(Do not fix the closer mechanisms in place yet).

Fix the mounting plate using the 11 off M6 x 16mm machine screws provided (assumes steel doors and that all possible fixing points are used).

### **Installation – Step Three**

Mounting **the lower\*** 4040XP-3071.US28 Closer Mechanism – Part #1 to the 4040XP-TANDEM.PLATE.US28

Ensure the CSK holes on the front of the casting are used. Do not adjust the hydraulic valves or the spring power dial at this point. Fix to the plate using 4 off M6 x 50mm closer mechanism mounting bolts provided.

**\*Labelled accordingly**

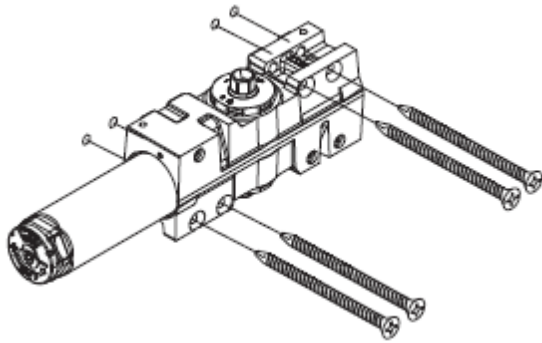

### **Installation – Step Four**

Mounting **the upper\*** 4040XP-3071.US28 Closer Mechanism – Part #1 to the 4040XP-TANDEM.PLATE.US28 via the 4040XP-TANDEM.BUSH connector – Part #8

Place the 4040XP-TANDEM.BUSH connector onto the lower mechanism pinion shaft. Guide the upper closer mechanism's lower pinion shaft into the bush connector. If necessary, use a rubber mallet to tap the bush connector and the upper closer mechanism fully into place. Ensure the CSK holes on the front of the casting are used. Do not adjust the hydraulic valves or the spring power dial at this point. Fix to the plate using the remaining 4 off M6 x 50mm closer mechanism mounting bolts provided.

**\*Labelled accordingly**

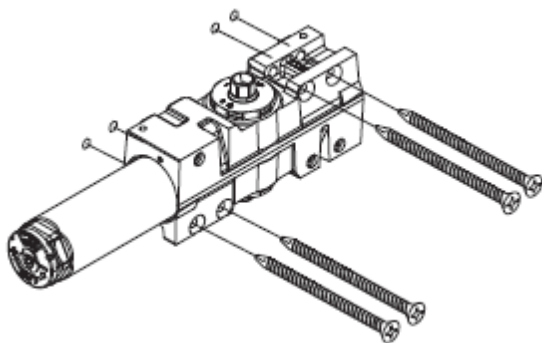

At this stage, do not fix the closer covers in place since you will need access to the hydraulic valves and the spring power dials for final adjustment. Do not adjust the hydraulic valves or the spring power dials at this point.

You now have both closer mechanisms in place on the mounting plate (see page 8) – you will notice the lower mechanism has a black mark at the bottom of the pinion shaft. This is used to align the arm correctly on the shaft for pre-load purposes (see below).

### **Installation – Step Five**

Mounting the 4040XP-3077.US28 Regular Duty Door Closer Arm – Non-Handed – Part #6

#### **Part One (Attaching the Arm)**

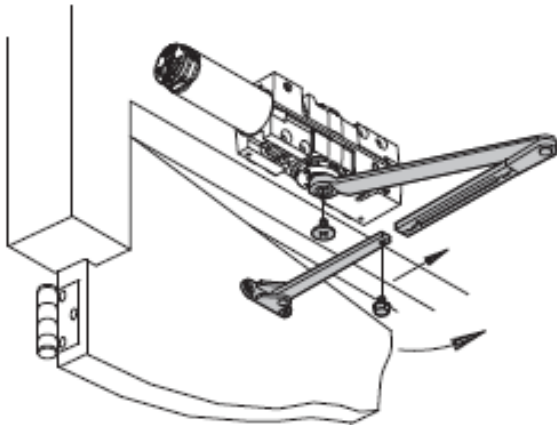

Place the closer arm hex hole onto the bottom of the lower pinion shaft ensuring the two marks (one on the pinion shaft and one on the arm hex hole) align correctly. Once the closer arm is in position use a rubber mallet to gently tap the arm in place fully. Use the 4040XP-159 Arm Screw – Part #4 to secure the installation.

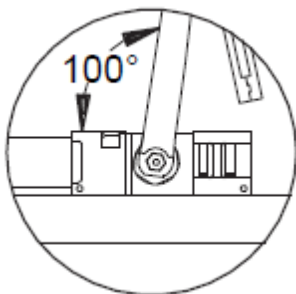

The hex hole at the end of the closer arm engages with the lower closer mechanism pinion shaft at a 100° angle to the closer

← view for left hand (LH) doors from the underside of the installation.

#### **Part Two (Main Arm Pre-Load)**

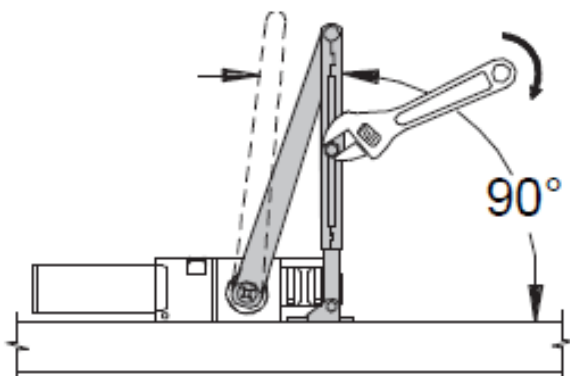

Pre-load the arm to 90° as shown - Rotate the main arm such that the fore arm meets the door at a 90° angle. This will ensure the closer pulls the door fully into the frame once the installation is complete; providing optimum control through the closing arc.

## Installation – Step Six

Adjusting the installation for power and hydraulic control.

Both closer mechanisms remain exposed on the mounting plate as shown below (left hand doors – right hand doors will be a mirror image).

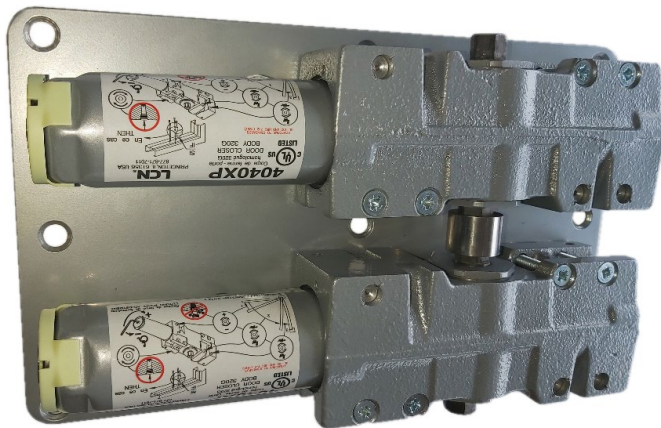

In detail – per mechanism:

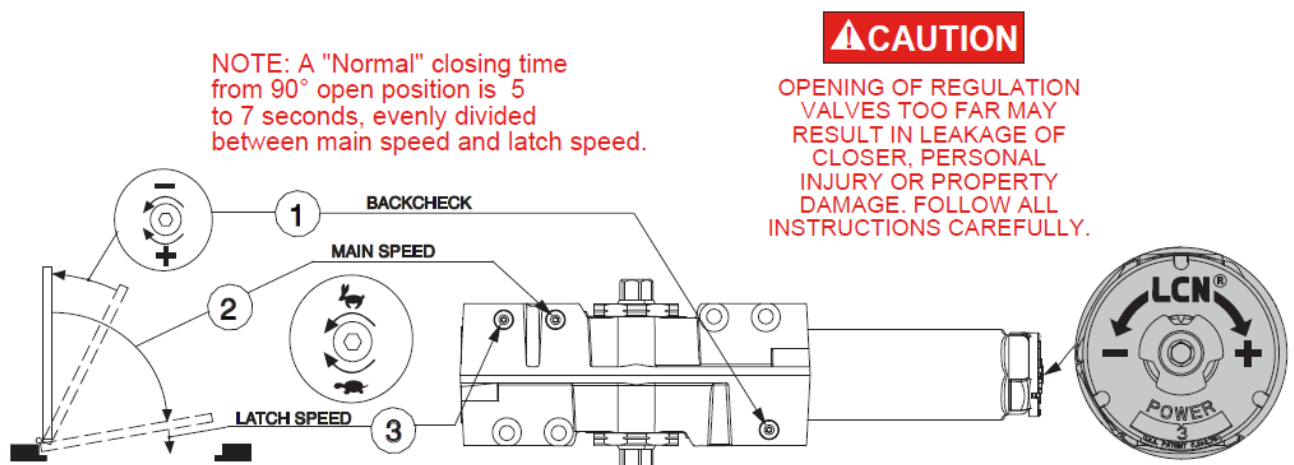

Before attempting to adjust the closer for power or speed open the door back to the maximum angle to check operation. If the door closes fully into the frame in a satisfactory manner, you do not need to make any adjustment.

If adjustment is required you must ensure each mechanism is adjusted identically, otherwise the two mechanisms will be competing with one another and control will be compromised.

**For detailed guidance on adjustment please refer to the document 'LCN Closers – Important Notes on Adjustment' in the appendix to these instructions (see pages 10 & 11).**

**NB** - Once correctly adjusted you should never need to return to the closer mechanism unless external circumstances change.



## Installation – Step Seven

Fixing the 4040XP-72MC.US28 Metal Closer Covers – Part #3 and Part #5

Before fixing the covers check both of the mechanisms for horizontal alignment. There is some tolerance even when fixed firmly to the mounting plate.

### Upper Cover – Fix this cover first

You will notice the upper 4040XP-3071.US28 Closer Mechanism has the 4040XP-31 Cover Screws in place already. Select the Upper Cover – cut bottom only to accommodate the bush connector with U slots for fixing - carefully slide this over the upper 4040XP-3071.US28 Closer Mechanism. Using the smaller (3/32) Allen key, tighten the two screws to secure the cover in place.

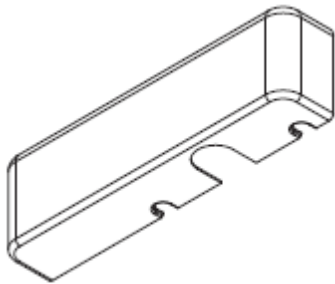

### Lower Cover – Fix this cover second

Fixing the lower cover is a little more straightforward since you will have clear access to the fixings. Select the Lower Cover – cut top & bottom to accommodate the lower pinion shaft for the arm & the bush connector - carefully slide this over the lower 4040XP-3071.US28 Closer Mechanism. The cover screws can be found in the main fixings pack with the rest of the fixings. Using the smaller (3/32) Allen key, tighten the two screws to secure the cover in place.

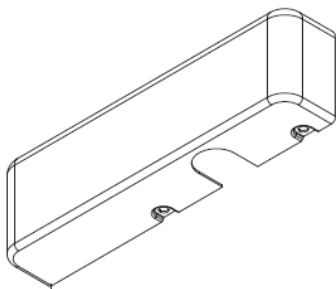

Check the covers for horizontal alignment.

## Appendix - I

### LCN CLOSERS - IMPORTANT NOTES ON ADJUSTMENT

#### Summary –

All LCN door closers have a minimum of 3 regulating (hydraulic) valves and a separate spring power adjustment where the closer is not a fixed power size. All closer mechanisms equipped with a 'delay action' feature will have an additional 4th valve. The 4040XP and 4041 mechanisms include a 5th valve on the reverse side of the mechanism which must be screwed in fully when the closer is to be fixed in the parallel arm (fig. 6) application, otherwise ignore this valve.

It is important to understand, in general terms, that the spring power setting only will give you the necessary ability to close the door into the frame (you can increase spring power with a simple Allen key adjustment). Once you are happy with this adjustment you should then fine tune the hydraulic settings which will control speeds over the opening and closing arcs. Increasing the closing speed (and ignoring power adjustment) will not solve potential problems so far as closing is concerned. Final adjustment (upon installation) takes time to achieve but with a little patience will result in a solution which closes the door correctly and quietly on each occasion. You will never need to return to the closer.

The recommended closing time provided by a properly adjusted door closer is between 5 – 7 seconds from 90° open to fully closed.

#### Detailed Adjustment Routine -

When you are happy the closer is installed in accordance with the template and the closer arm has the necessary pre-load (see installation instructions), make adjustments below (in this order) as required:

**Spring Power Adjustment\***, is located on the end of the spring tube (5/32 Allen key). It is used to adjust the spring's power (force to close the door). Clockwise adjustment gives the closer more closing power and makes the door harder to open. Anti-clockwise adjustment gives the closer reduced closing power and makes the door easier to open.

Closers are designed to control doors in calm conditions. Where air pressure differentials are present (for example at stairwells and hospital theatre doors) and where doors open into relatively small spaces you must consider combining a number of available options. These include; increasing the available spring power, installing closers at the minimum angle template setting and adding ventilation either on or immediately adjacent to doors\*\*.

**Note 1** - Parallel arm applications are best avoided where optimum power and control is required.

**Note 2** - No amount of adjustment or repositioning of closers will provide the necessary power to overcome strong winds at perimeter doors. You must allow winds to abate before expecting a mechanical overhead closer to perform correctly. Similarly, opening windows and doors in connected areas throughout a building will affect a closer's performance. This is unavoidable.

For outward opening perimeter doors in exposed conditions always add the Cush-N-Stop arm and adjust the back check valve (see below) to protect doors and frames.

(\*Universal, power adjustable closers only – excludes 2000 series, 3000 series and 4016/4116 closers) (\*\*extreme situations only)

The **Back Check Valve**, (valve #1 - see the instructions) controls the back check intensity (3/32 Allen key). Use the back check feature to protect the door, frame and closing mechanism. Back check slows the door during the opening arc; should it be thrown open or should the wind catch the door and blow it open. If you need to make the back check a little more responsive, turn the valve clockwise - this will give you a stronger back check. Turning the valve anti-clockwise will give you a weaker back check.

Back check must not be relied upon to stop the door. For parallel arm installations the Cush-N-Stop feature can be used for dead stop angles between 85-110° from closed. For other mounting applications always use a wall mounted or floor mounted stop.

The **Main Speed Valve**, (valve #2 - see the instructions) controls the main closing speed of the door (3/32 Allen key). This area is measured from the door's widest open position down to 15° from closed – at which point the latch action (see below) takes over. Turning the valve clockwise will reduce the door's closing speed. Turning the valve anti-clockwise will increase the door's closing speed.

The **Latch Speed Valve**, (valve #3 – see the instructions) controls the latching action of the door (3/32 Allen key). The latching action is the final 15° of closing – as the door returns to the frame/stop. Turning the valve clockwise will reduce the door's speed to ensure it closes quietly into the frame without slamming. Turning the valve anti-clockwise will increase the door's speed adding additional momentum where required – perhaps to overcome a stubborn latch or tightly fitting seal.

#### **Important –**

Correctly specified LCN door closers – i.e., those installed on doors (in calm conditions) where size and weight parameters do not exceed recommended maximums - will be capable of closing doors in a safe and controlled manner if adjusted correctly. If the closer's spring is not sufficiently powerful to close the door **do not** be tempted to 'over adjust' speed control valves (valves #2 & #3) to address the problem. Valves which are backed out to the end of their thread will be dangerously close to 'popping' their seal during an opening or closing arc. Hydraulic fluid will gush from the mechanism and the closer will be a write-off. Warranty does not cover incorrectly specified and/or adjusted door closers.

Where there remains any doubt over suitability and/or correct adjustment methods please contact Relcross Door Controls. We will be pleased to assist wherever possible.

**Note 4** - To adjust any LCN door closer to its Factory Default Setting - turn all adjustment valves (back check, main speed, and latch speed valves) fully clockwise and then back out 1.1/2 turns anti-clockwise.

**Note 5** - If the spring force adjustment is set to the very minimum force on 1260 series closers, the internal spring adjustment plate may rest in a safety area of the threaded spring adjustment rod. To address this, open the door to approximately 30° to engage the closer spring and turn the power adjustment screw approximately 6 full turns clockwise.

For full installation and adjustment instructions on your particular closer model (including templates) see [Installation Instructions](#) here.