

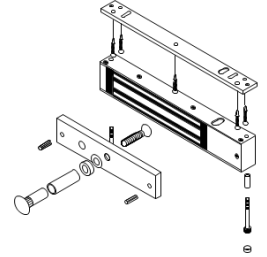

relcross door controls®

distributors of **ANSI** grade & **CE** marked commercial door hardware

272 Series Electro-Magnetic Locks Installation Instructions



272 & 272M

Holding Force—272 Kilos | Current Draw—480mA @ 12Vdc/254mA @ 24Vdc | Optional L & ZL Brackets



2722 & 2722M

Holding Force—272 Kilos (per Leaf) | Current Draw—480mA @ 12Vdc/240mA @ 24Vdc | Optional L & ZL Brackets

272 & 272M Components & Applications

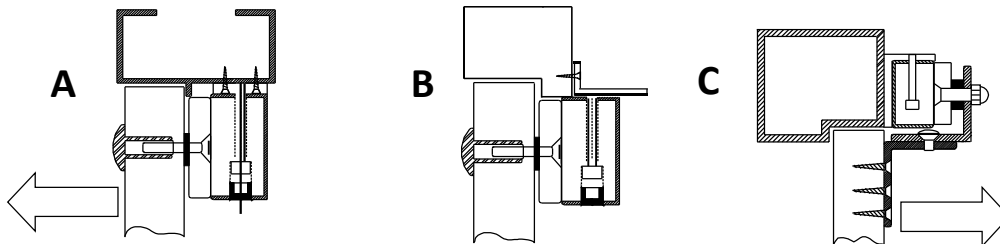

- | | | |
|----------|-----------------------------------------------------------------------------------------|------------------------------------------------------------------------------------------------------------------------------------------------------------------------|
| A | Specify:
272 (M) | Application—Side Fix (Standard)
Doors opening away from the secure side with reveals >44mm require no additional brackets |
| B | Specify:
272 (M)
w. 272L.SAA L (Spreader) Bracket | Application—Side Fix (Standard) w. L (Spreader) Bracket
Doors opening away from the secure side with reveals <20mm will always require L (spreader) bracket* |
| C | Specify:
272 (M)
w. 272ZL.SAA Z Bracket
& L Face Fix Conversion Bracket | Application—Face Fix w. ZL Bracket
Doors opening towards the secure side with reveals <20mm will always require the ZL bracket* |

** for all other scenarios consult the sales office.*

NB—all drawings in this document are indicative only

A—272 & 272M Application Side Fix (Standard) - Armature Plate

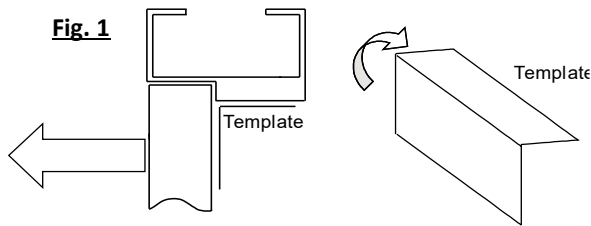
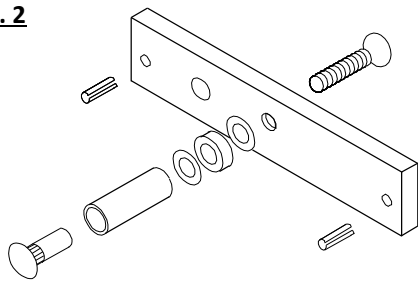

Fig. 1

Step 1

- The reveal should be >44mm and provide a sound fixing surface for the magnet's mounting plate.
- Fold the template along the dotted line and offer it to the closed door/head frame, taking note of the handing (Fig. 1).
- For optimum secure hold place the template edge against the vertical jamb opposite the pivot point. If necessary, tape the template in place prior to drilling guide holes.

Fig. 2



Step 2

- Only drill the 16mm hole for the armature plate for timber doors if using the bolt sleeve. The sleeve suits timber doors @ 44mm. (Fig. 2) - for all other installations, including hollow metal doors and reinforced doors please see below.

Fig. 3

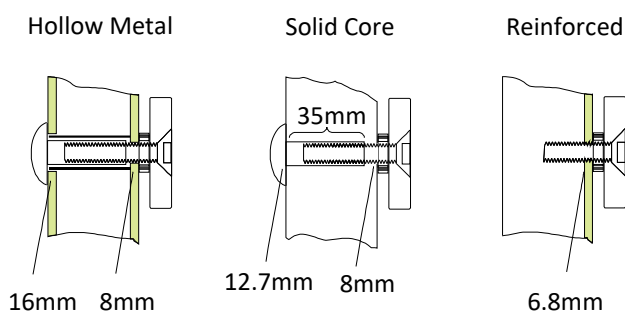

Step 3

- Hollow Metal— drill 16mm/8mm holes (Fig.3)
- Solid Core— drill 12.7mm /8mm holes (Fig. 3)
- Reinforced—drill 6.8mm for M8 (1.25mm thread) (Fig. 3)
- The standard sex bolt assembly suits doors >35mm and <50mm. For thicker doors you will need to provide a longer CSK bolt (M8).

Fig. 4

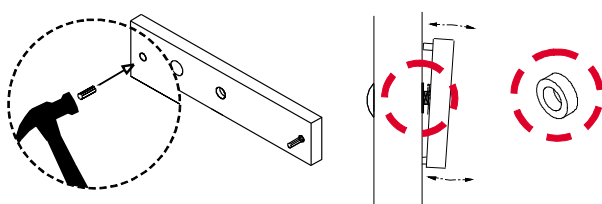

Step 4

- Tap the two guide pins into the back of the armature plate and assemble using two steel washers and one rubber washer between the door face and the rear of the plate. This will ensure the armature plate is free to 'float' about its fixing. (Fig. 4)

272 & 272M Side Fix Magnet (Application A)

Fig.5

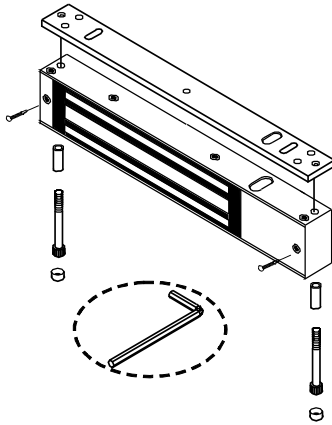

Step 5

- Prepare the lock body for mounting by removing the mounting plate from the magnet. In this order—remove the two screws at either end of the magnet face. This exposes the hex head bolts (accessible via the underside) which fix the mounting plate in place. Remove the bolts to release the mounting plate. (Fig. 5)

Fig.6.1

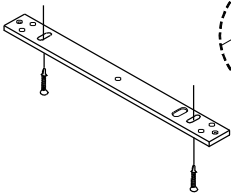

Fig.6.2

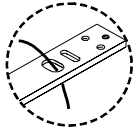
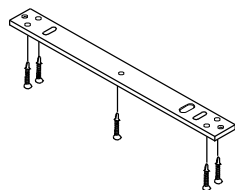

Fig.6.2



Step 6

- Using the pre-prepared guide holes, align the mounting plate (with the CSK clearance holes exposed) and fix to the underside of the reveal using the self tapping screws via the CSK slotted holes at either end of the mounting plate. Adjust the plate to ensure it can be set parallel to the closed face of the door. (Fig. 6.1)
- Remove the mounting plate temporarily and drill the cable access hole. Feed the cable through and fix the plate permanently using all seven self tappers (Fig. 6.2)
- When all is aligned correctly fix the five additional self tappers and secure the mounting plate. (Fig. 6.3)

Fig.7

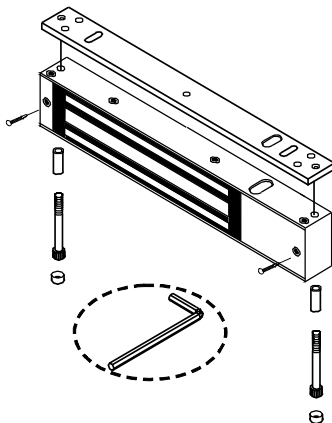

Step 7

- Fix the magnet to the underside of the mounting plate using the hex head bolts (x2), sleeves and caps. (Fig. 7)
- Replace the locking screws via the magnet's face to protect the hex head bolt fixings.

Fig.8

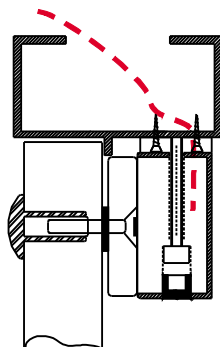

Step 8

- With RTE switches in place, apply power to the magnet—12Vdc or 24Vdc (see **connection instructions on page 6**) and check the door is secure.
- When the door is closed the final installation should appear as shown here (Fig. 8)
- Ensure the 'floating' armature plate is free to engage the magnet face fully and that the door is secure.

272 & 272M Side Fix Magnet w. L (Spreader) Bracket (Application B)

Fig.9

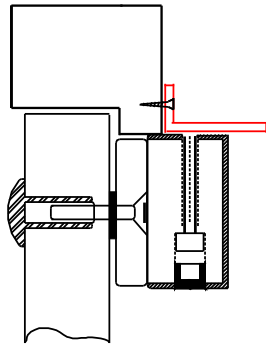

Step 9

- This bracket aids mounting of 272 magnets (all models) on outward opening doors (i.e. doors opening away from the secure side) with narrow reveals.
- Specify where you have a flush frame/door or reveals to max. 20mm. Mounting is adjustable in four increments from 0mm to 20mm in combination with the armature washer stack. (Fig.9)
- NB - without this bracket the 272 magnets require a minimum reveal of 44mm. Where reveals fall between 20mm - 44mm a custom spreader plate will be required. Please contact the sales office.

Fig.10

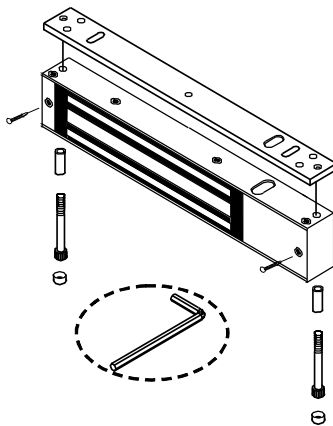

Step 10

- Prepare the lock body for mounting by removing the mounting plate from the magnet. In this order—remove the two screws at either end of the magnet face. This exposes the hex head bolts (accessible via the underside) which fix the mounting plate in place. Remove the bolts to release the mounting plate. (Fig. 10)
- Dispose of the mounting plate—to be substituted with the L bracket.

Fig.11

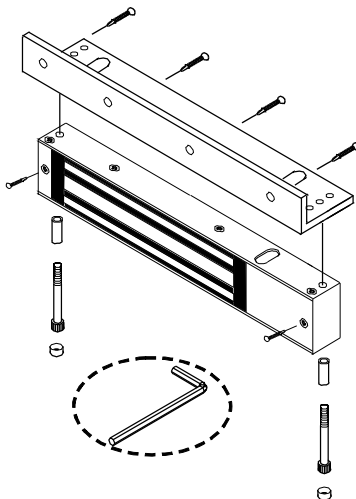

Step 11

- Offer the L bracket to the face of the transom and fix in place using screws appropriate to the header construction—via 4 CSK clearance holes. (Fig. 11)
- Feed the cable through the L bracket and fix the magnet to the underside of the L bracket using the hex head bolts (x2), sleeves and caps. (Fig. 11) - Use the template (Fig. 1—Step 1) to determine the correct lateral mounting position.
- Replace the locking screws via the magnet's face to protect the hex head bolt fixings.

Fig.12

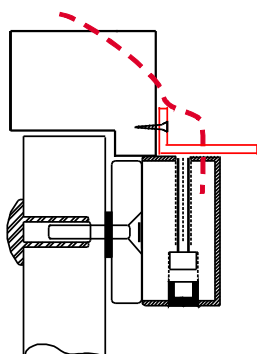

Step 12

- With RTE switches in place, apply power to the magnet—12Vdc or 24Vdc (**see connection instructions on page 6**) and check the door is secure.
- When the door is closed the final installation should appear as shown here (Fig. 12)
- Ensure the 'floating' armature plate is free to engage the magnet face fully and that the door is secure.

272 & 272M Side Fix Magnet w. Z Bracket & L Face Fix Conversion Bracket

(Application C)

Fig.13

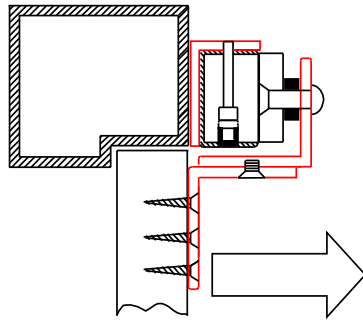

Step 13

- This bracket combination aids mounting of 272 magnets (all models) in the face fix application on inward opening doors (i.e. doors opening towards the secure side). (Fig. 13)
- The L bracket fixes to the face of the transom (i.e. above the door) to allow the magnet to be fixed in position. The Z bracket is fixed to the door. Armature mounting is adjustable in three increments to accommodate reveals from 0mm** to 20mm**.
- ** The Z bracket will require packers at the door to offset the washer stack (4mm).

Fig.14

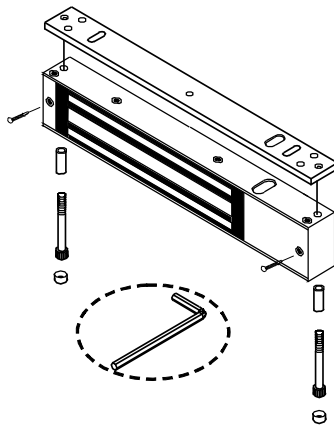

Step 14

- Prepare the lock body for mounting by removing the mounting plate from the magnet. In this order—remove the two screws at either end of the magnet face. This exposes the hex head bolts (accessible via the underside) which fix the mounting plate in place. Remove the bolts to release the mounting plate. (Fig. 13)
- Dispose of the mounting plate—to be substituted with the ZL bracket.

Fig.15

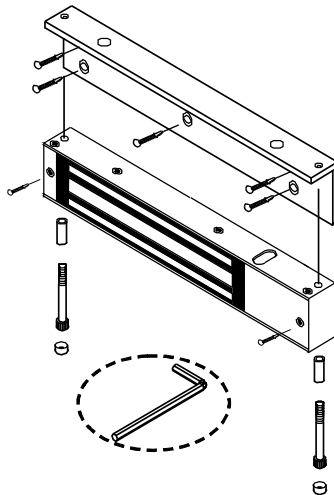

Step 15

- Offer the L bracket to the face of the transom and fix in place using screws appropriate to the header construction—via 4 CSK clearance holes. (Fig.15)
- Ensure the underside of the assembly sits flush with the underside of the reveal and that the door is free to pass underneath.
- Feed the cable through the L bracket and fix the magnet to the underside of the L bracket using the hex head bolts (x2), sleeves and caps. (Fig. 15)
- Replace the locking screws via the magnet's face to protect the hex head bolt fixings.

Fig.16

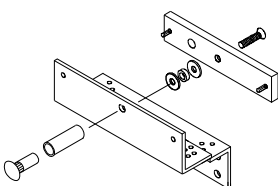
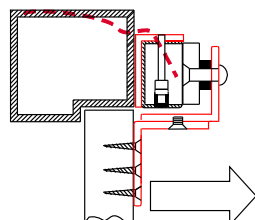

Fig.17



Step 16

- Assemble the armature plate as shown—taking care that it is free to float about its fixing. (Fig 16) *See also Fig 4, Step 4*
- Offer the two part Z bracket to the closed door and magnet face ensuring the armature sits squarely over magnet. Mark the fixing position of the Z bracket on the door. Fix securely in position.
- With RTE switches in place, apply power to the magnet—12Vdc or 24Vdc (see connection instructions on page 6) and check the door is secure.
- When the door is closed the final installation should appear as shown here (Fig. 17)

272 & 272M Wiring Instructions & PCB Schematic

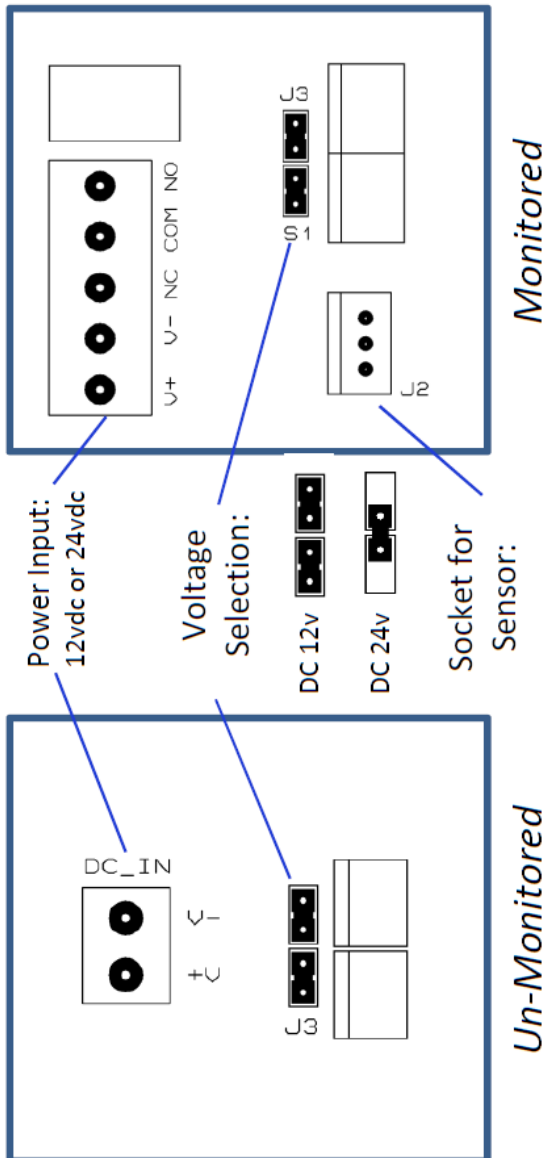

12Vdc Input

- Required power 0.5Amp (Minimum)
- Check jumper for 12Vdc operation
- Connect –VE lead from the 12Vdc power supply to -
Connect +VE lead from the 12Vdc power supply to +

24Vdc Input

- Required power 0.25Amp (Minimum)
- Check jumper for 24Vdc operation
- Connect –VE lead from the 24Vdc power supply to -
Connect +VE lead from the 24Vdc power supply to +

C: Contacts

- Relay voltage free contacts are rated 1Amp @ 24Vdc for safe operation, do not exceed.
- NO Switch—Connect wires to C and NO
- NC Switch—Connect wires to C and NC

Lock Status Sensor

- NO switch: NO & C
- NC Switch: NC & C

Recommended Power Supplies

Relcross **00-PS01 12Vdc** 2.0 Amp Power Supply/Fire Relay - This continuously rated power supply is shipped with a fire relay by default.

Relcross **00-PS02 - 24Vdc** 1.0 Amp Power Supply/Fire Relay—This continuously rated power supply is shipped with a fire relay by default