



26630-00

7255

IVES®

Bottom Center Pivot

Installation Instructions

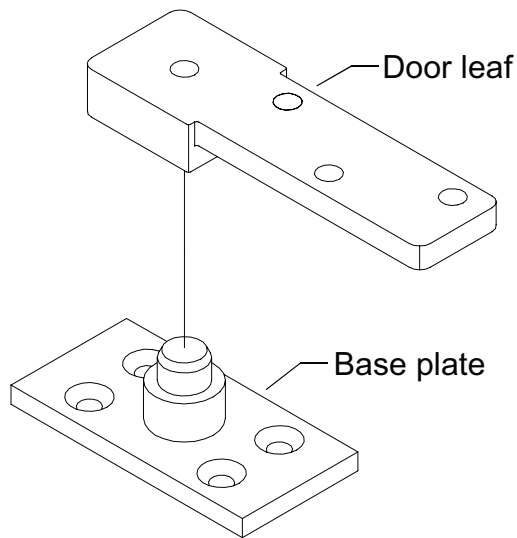

1. Prepare and mortise bottom of door and floor to receive pivot set. Determine pivot location using dimensions on reverse side. Depth of mortise in the bottom of door will determine clearance. **Be sure to properly locate and mark pivot center point of the base plate.**
2. Locate, drill, and tap 1/4-20 mounting holes for metal door. Locate and drill pilot holes for #14 wood screws for wood door. Mount door leaf in bottom of door with 1/4-20 x 3/4" FHMS or #14 FHWS screws provided.
3. Drill four 1/2" dia. x 3/4" deep holes in floor per template for base plate mounting. **Pivot point of top pivot set must be plumb with bottom pivot point.** Insert anchor pins into holes and expand with tool. Insert base plate screws provided. Grout anchor pins in place. After grout has set, remove base plate screws.
4. Place base plate over anchor pin holes. Fasten to floor with base plate screws. Tighten securely.
5. If using a threshold, install threshold at this time.
6. Install top pivot set and hang door. Refer to top pivot set instructions.
7. If vertical height adjustment is necessary, use shims between door bottom and pivot leaf to increase clearance. To decrease clearance, mortise in door must be made deeper.

⚠ CAUTION ⚠

Improper pivot set installation can lead to personal injury or property damage. Follow all instructions carefully. For questions contact Technical Support at 01380 729600.

⚠ NOTE ⚠

It is very important for installer to verify that center line of top pivot point lines up with center line of bottom pivot point before final installation.

Door Leaf

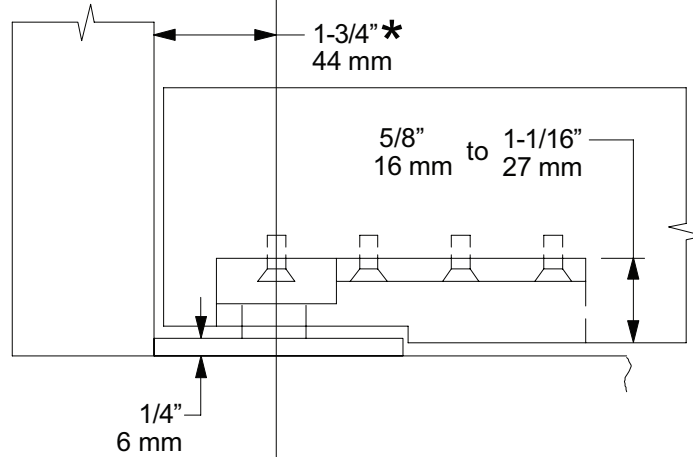
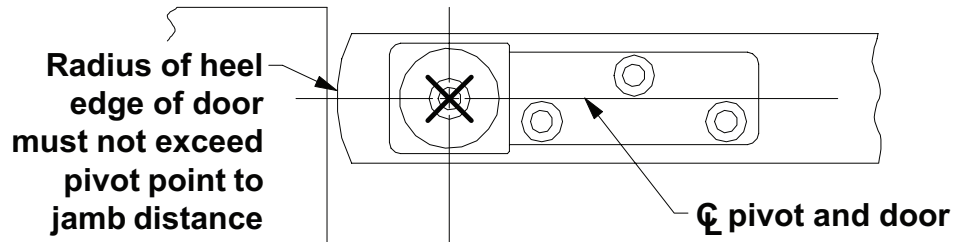

* Pivot center may be varied as needed. The minimum distance is 1-3/4" as shown.

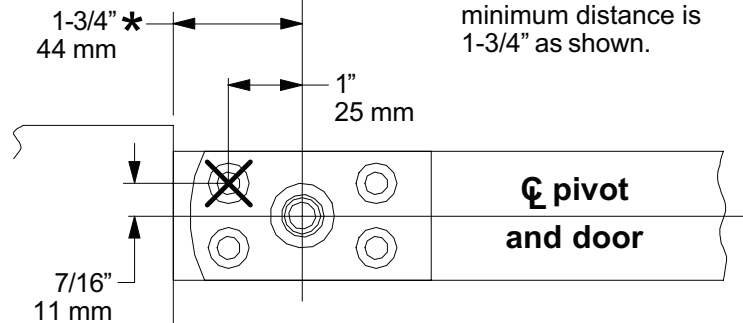

Pivot Base