

# VON DUPRIN

## Conversion Instructions

### 33/35, 33A/35A, and 98/99 Series Hex Dogging to Cylinder Dogging

#### GENERAL INFORMATION

The cylinder dogging (CD) kit is for field conversion of 33/35, 33A/35A, and 98/99 hex dogging to cylinder dogging.

This kit requires a standard 1-1/4" mortise cylinder. A cylinder is not furnished with this kit and must be specified when ordering.

#### PARTS LIST

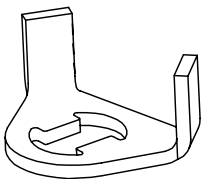

Old Design  
(pre 9/97)

Actuator Arm

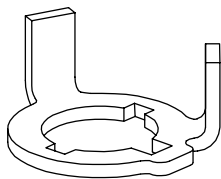

Current Design

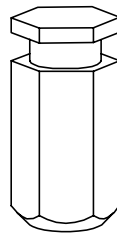

CD Dogging Plug

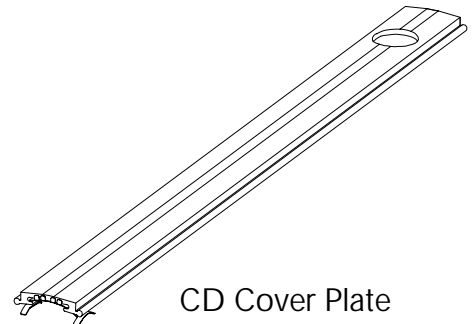

CD Cover Plate

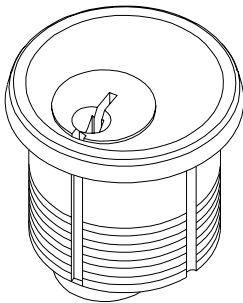

Standard 1-1/4"  
Mortise Cylinder  
(not provided)

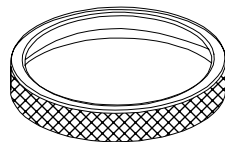

Cylinder Lock Nut

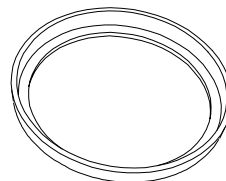

Cylinder Collar

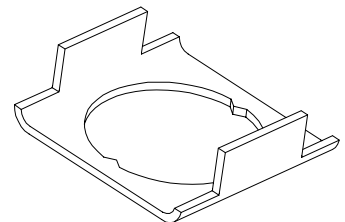

Cylinder Locating  
Washer

#### TOOLS NEEDED

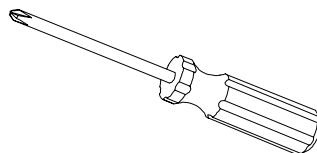

Phillips Screwdriver

## OLD DESIGN (PRE 9/97)

### 1 Disassemble and remove dogging shaft

- 1.1. Remove end cap and end cap bracket.
- 1.2. Slide off cover plate.
- 1.3. Remove hitch pin.
- 1.4. Remove dogging shaft.

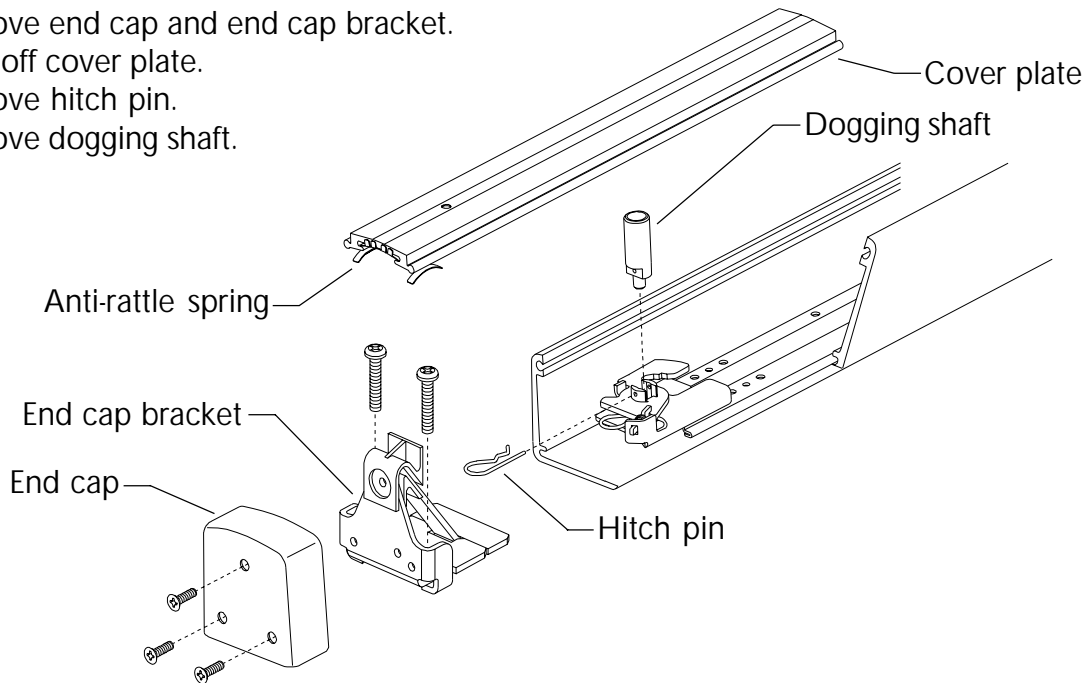

### 2 Install actuator arm and reassemble

- 2.1. Place actuator arm on post.
- 2.2. Replace hitch pin.
- 2.3. Assemble cylinder in new CD cover plate (see page 4).
- 2.4. Slide assembled CD cover plate on device keeping anti-rattle spring in place.
- 2.5. Replace end cap bracket and end cap.
- 2.6. Check device for proper dogging operation.

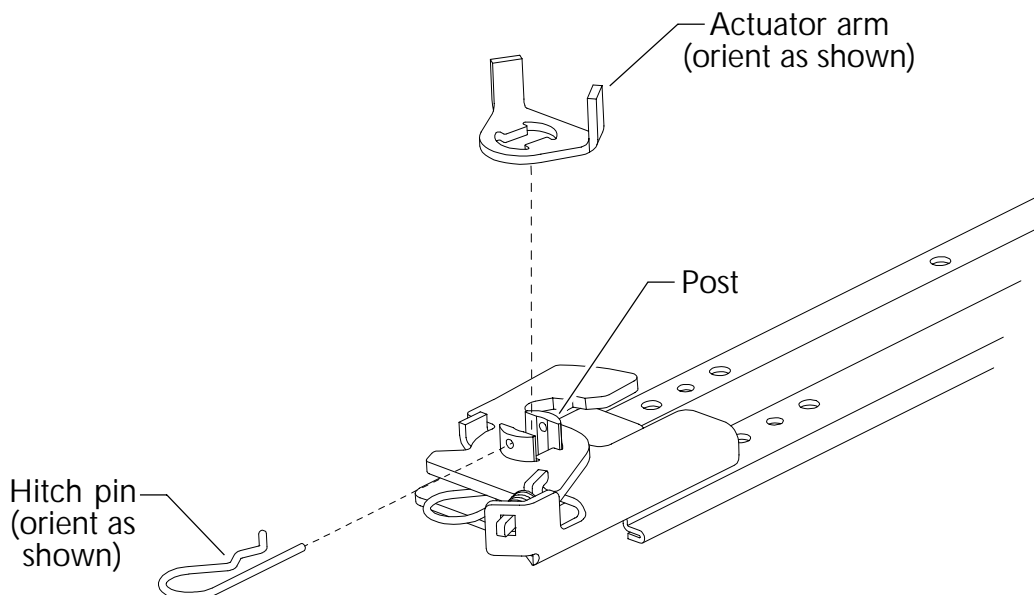

# CURRENT DESIGN

## 1 Disassemble and remove dogging shaft

- 1.1. Remove end cap and end cap bracket.
- 1.2. Slide off cover plate.
- 1.3. Remove dogging shaft by pulling straight up.

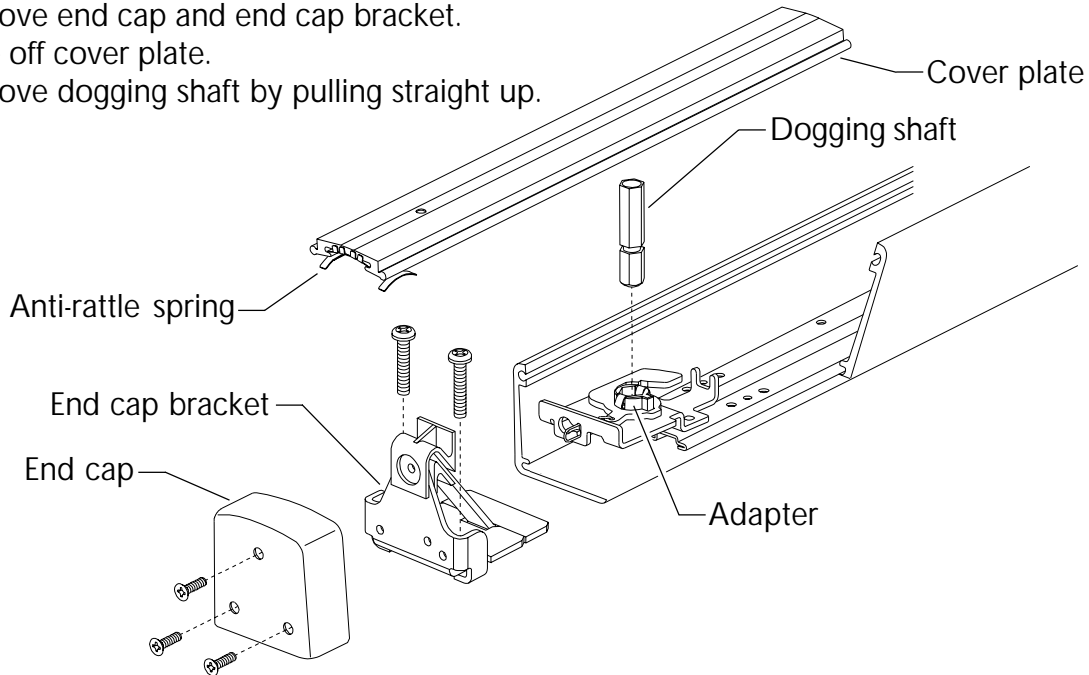

## 2 Install actuator arm and reassemble

- 2.1. Place actuator arm over adapter and press until parts snap together.
- 2.2. Insert CD dogging plug into hex hole in adapter and press until adapter spring snaps into top groove of CD dogging plug.
- 2.3. Assemble cylinder in new cover plate (see page 4).
- 2.4. Slide assembled cover plate on device keeping anti-rattle spring in place.
- 2.5. Replace end cap bracket and end cap.
- 2.6. Check device for proper dogging operation.

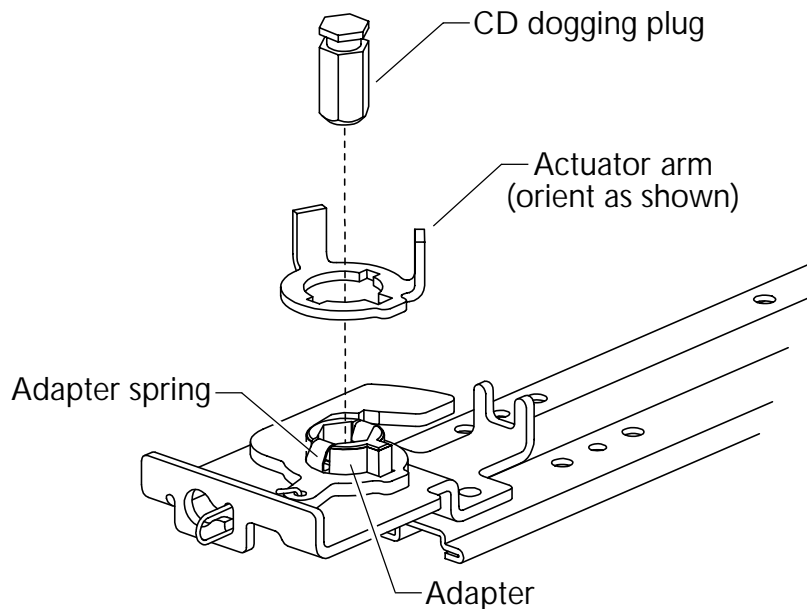

### 3 Install dogging cylinder

- 3.1. Remove mortise cylinder cam and replace in reverse position with key removed (Figure 3-1).
- 3.2. Insert key and rotate 180° (Figure 3-2A) so cylinder cam is in normal position (Figure 3-2B).
- 3.3. Assemble mortise cylinder and cylinder collar into CD cover plate, then install cylinder locating washer and secure cylinder with cylinder lock nut (Figure 3-3).
- 3.4. Remove key. Make sure cylinder and cylinder cam are in position shown in Figure 3-4 before sliding CD cover plate in place.

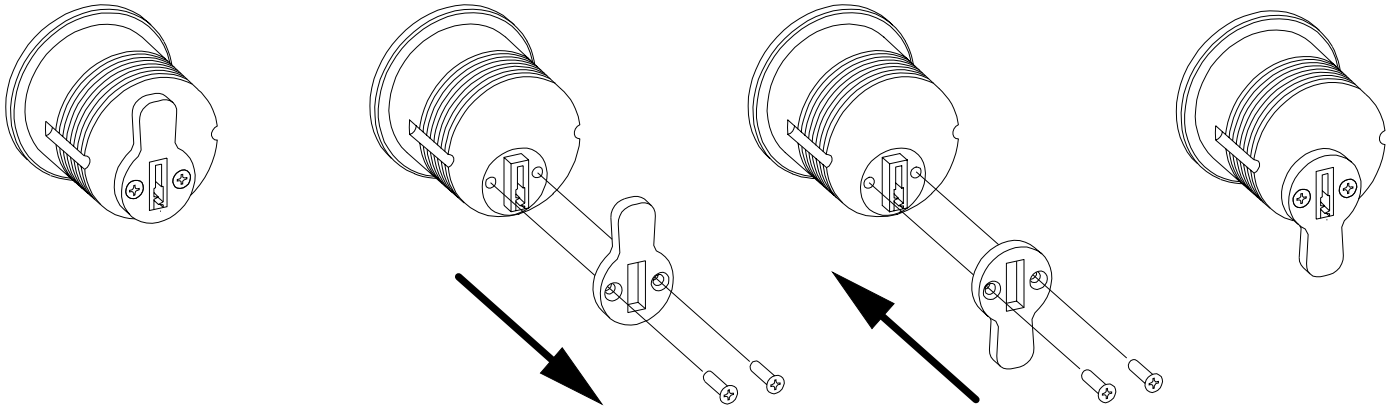

**Figure 3-1**

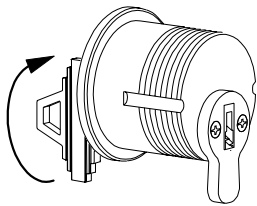

**Figure 3-2A**

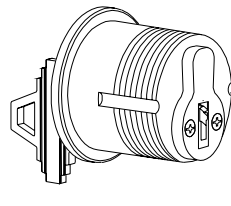

**Figure 3-2B**

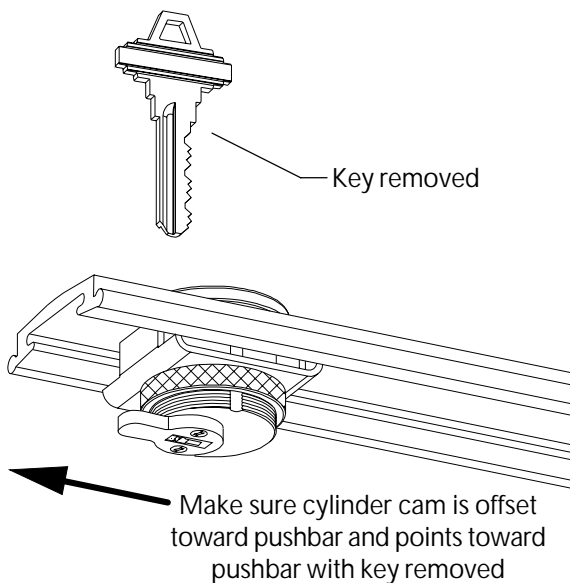

**Figure 3-4**

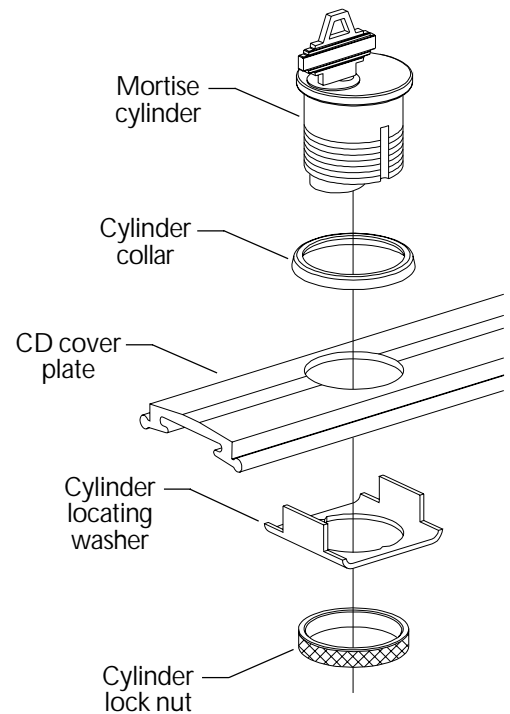

**Figure 3-3**