

**I (Fig. 1)**  
1071 EN 1-3

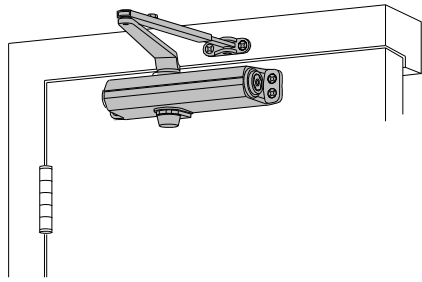

PULL SIDE MOUNT  
MONTAGE NORMAL  
MONTAJE EN EL LADO DE LAS BISAGRAS

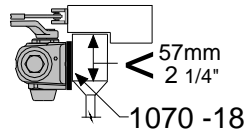
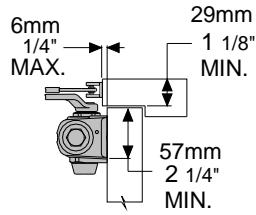

**II (Fig. 61)**  
1071 EN 1-3

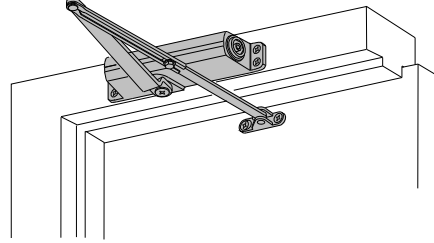

TOP JAMB MOUNT  
MONTAGE RENVERSÉ  
MONTAJE EN EL MARCO SUPERIOR

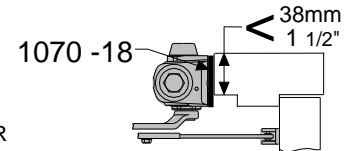
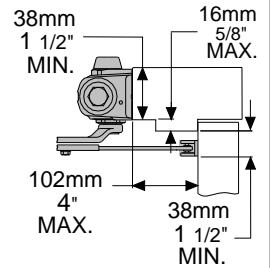

**III (Fig. 61)**  
1071 EN 1-3

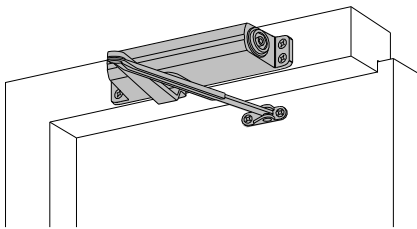

TOP JAMB MOUNT  
MONTAGE RENVERSÉ  
MONTAJE EN EL MARCO SUPERIOR

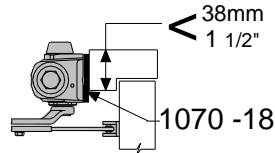
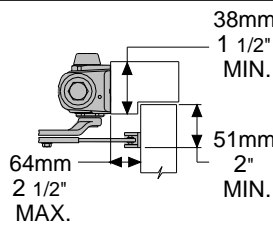

**IV (Fig. 66)**  
1071 EN 1-3

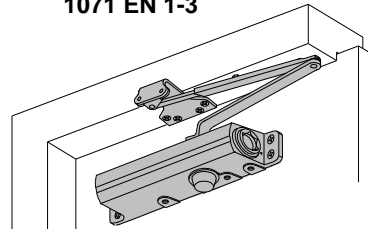

PUSH SIDE MOUNT - PARALLEL ARM  
MONTAGE BRAS PARALLELE  
MONTAJE EN EL LADO DE EMPUJE

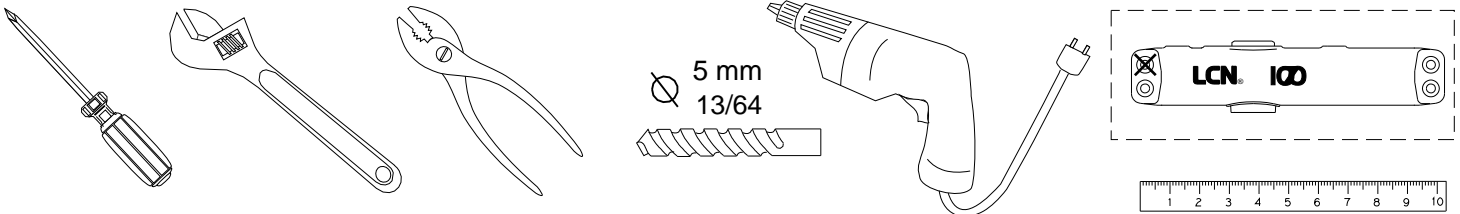
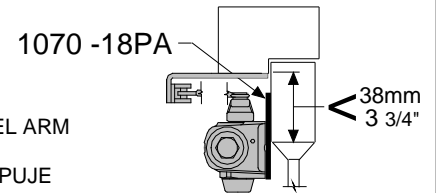
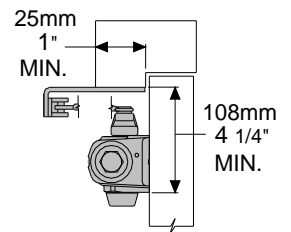

TOOLS REQUIRED / OUTILS REQUIS / HERRAMIENTAS REQUERIDAS

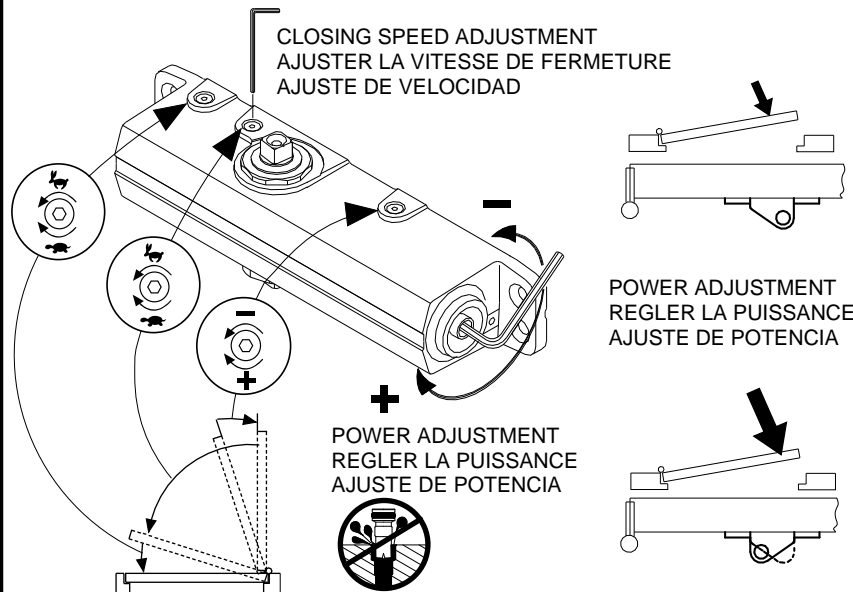

**MAXIMUM OPENING FORCE**  
FORCE D'OUVERTURE MAXIMALE  
ABERTURA RESISTENCIA MAXIMO

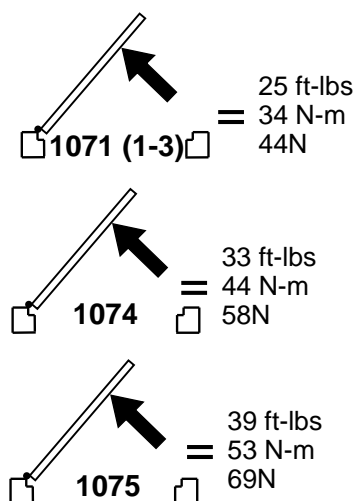

**NO MAINTENANCE REQUIRED**

**CAUTION**  
IMPROPER INSTALLATION OR REGULATION MAY RESULT IN PERSONAL INJURY OR PROPERTY DAMAGE. FOLLOW ALL INSTRUCTIONS CAREFULLY. FOR QUESTIONS, CALL LCN AT 800-526-2400

Thriftee®

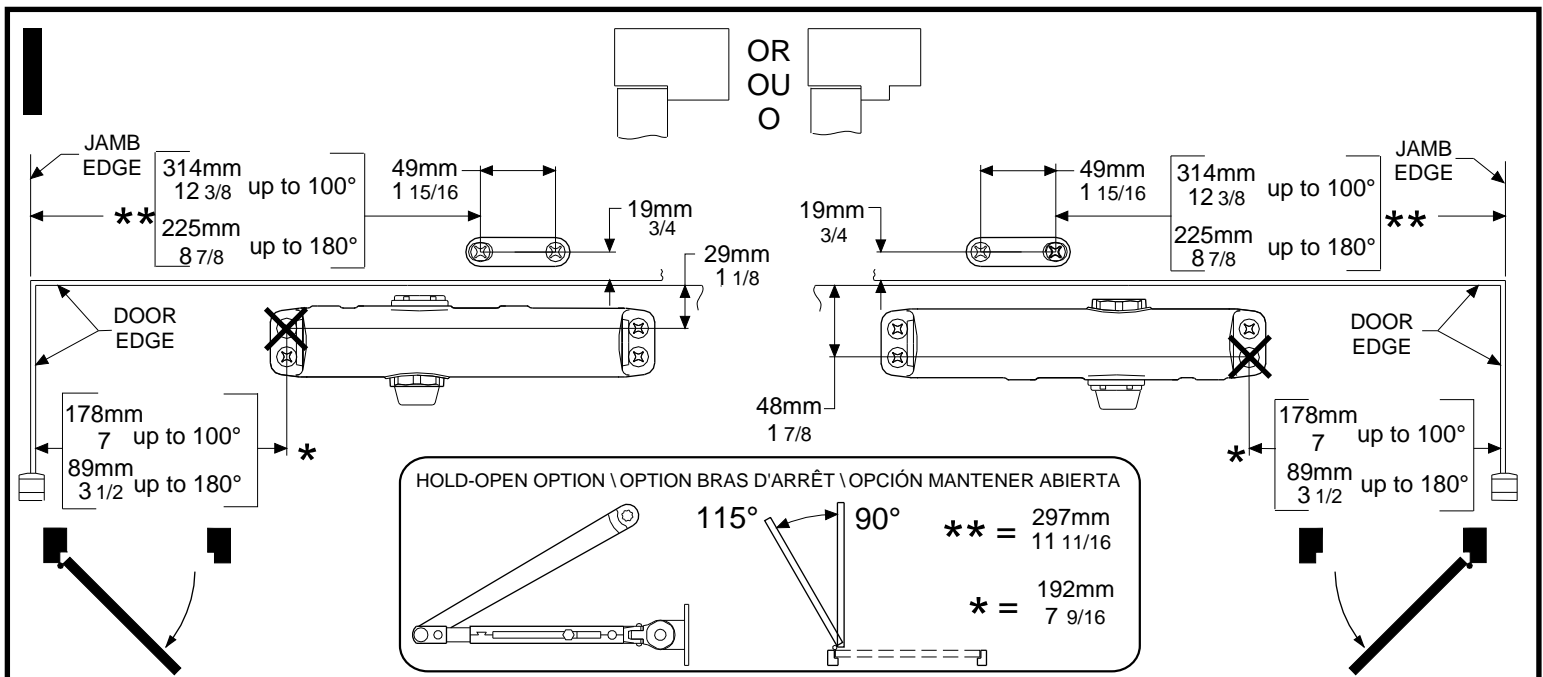

1.

|                  |     |
|------------------|-----|
|                  |     |
| 750mm -          | - 8 |
| 850mm (32"- 34") | - 4 |
| 950mm (36")      | 0   |

2.

MOUNT DOOR CLOSER / ROD & SHOE  
MONTAGE DU FERME-PORTE / BRAS SECONDAIRE  
MONTE EL CIERRA PUERTA / EL ZAPATO

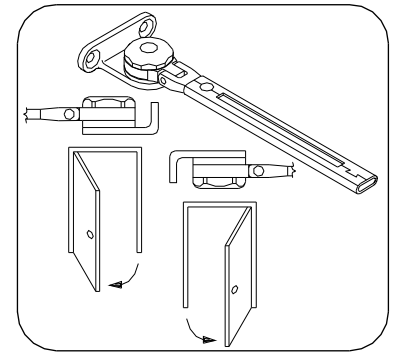
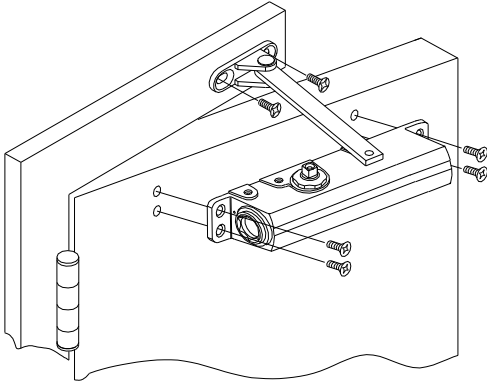

HOLD-OPEN OPTION  
OPTION BRAS D'ARRÊT  
OPCIÓN MANTENER ABIERTA

3.

ATTACH ARM, AS SHOWN  
FIXER LE BRAS, TEL QU'INDIQUÉ  
CONECTE EL BRAZO, COMO SE MUESTRA

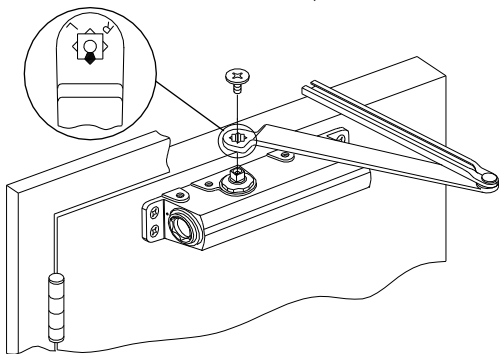

4.

ATTACH ARM AND ROD & SHOE  
LIAISON BRAS PRINCIPAL ET SECONDAIRE  
ENSEMBLE EL BRAZO CON LA VARILLA Y ZAPATO

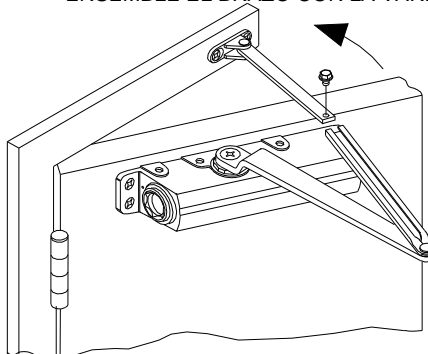

PRE-LOAD ARM  
REGLER LE BRAS  
PRE-CARGUE EL BRAZO

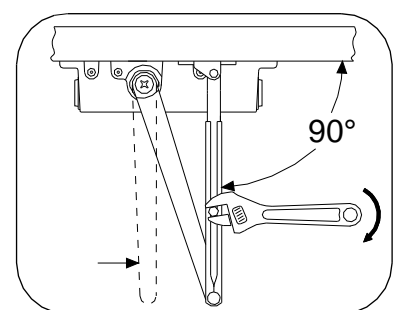

5.

HOLD-OPEN OPTION  
OPTION BRAS D'ARRÊT  
OPCIÓN MANTENER ABIERTA

ADJUST HOLD OPEN ANGLE  
REGLEZ L' ANGLE D' ARRÊT  
AJUSTE ÁNGULO DE ABERTURA

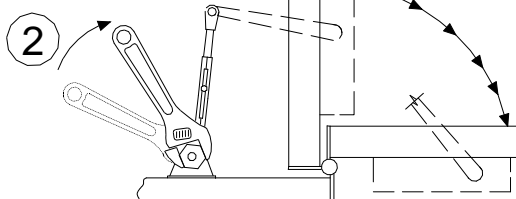
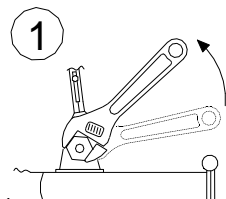

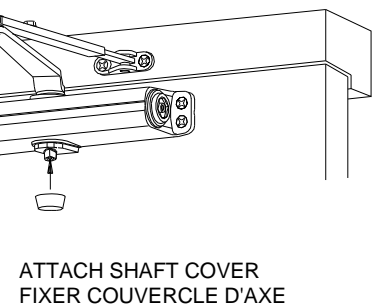

6.

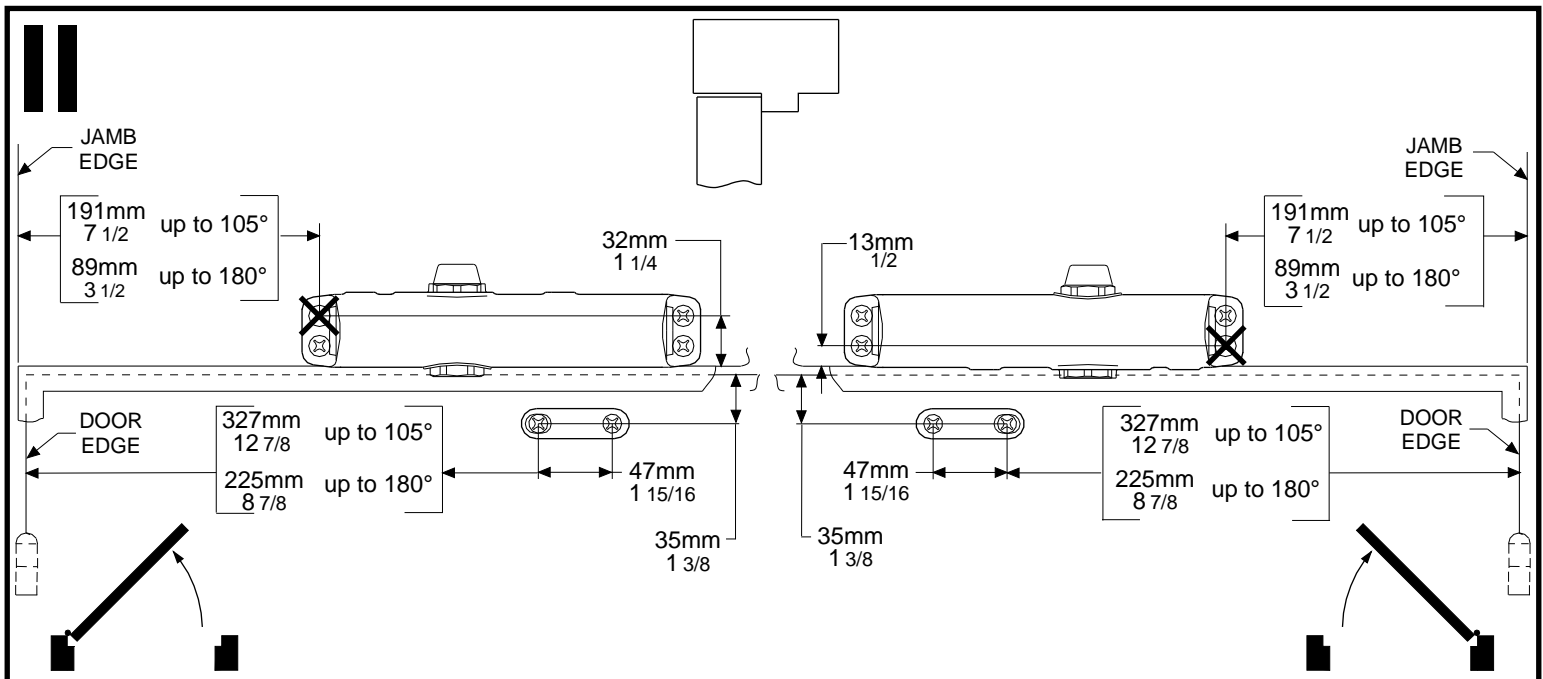

ATTACH SHAFT COVER  
FIXER COUVERCLE D'AXE  
CONECTE LA CUBIERTA DE PINON

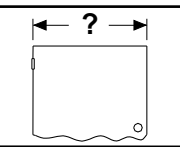

1.

|  |   |
|--|---|
|            |  |
| 750mm -  | - 8   |
| 850mm (32"- 34")   | - 4   |
| 950mm (36")  | 0   |

2.

MOUNT DOOR CLOSER / ROD & SHOE  
 MONTAGE DU FERME-PORTE / BRAS SECONDAIRE  
 MONTE EL CIERRA PUERTA / EL ZAPATO

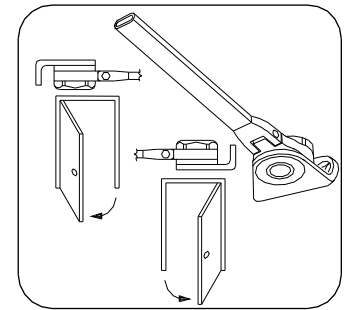
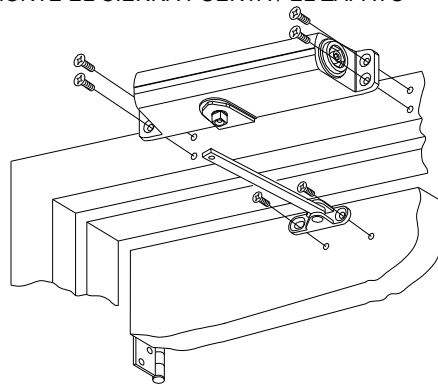

HOLD-OPEN OPTION  
 OPTION BRAS D' ARRÊT  
 OPCIÓN MANTENER ABIERTA

3.

ATTACH ARM, AS SHOWN  
 FIXER LE BRAS, TEL QU'INDIQUÉ  
 CONECTE EL BRAZO, COMO SE MUESTRA

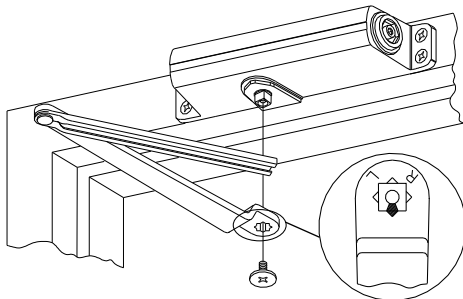

4.

ATTACH ARM AND ROD & SHOE  
 LIAISON BRAS PRINCIPAL ET SECONDAIRE  
 ENSEMBLE EL BRAZO CON LA VARILLA Y ZAPATO

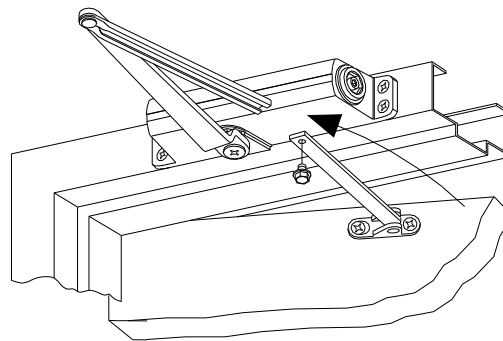

PRE-LOAD ARM  
 REGLER LE BRAS  
 PRE-CARGUE EL BRAZO

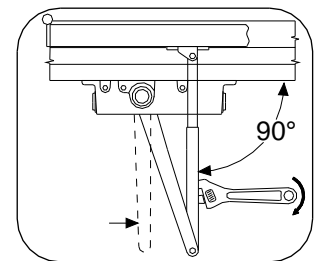

5.

HOLD-OPEN OPTION  
 OPTION BRAS D'ARRÊT  
 OPCIÓN MANTENER ABIERTA

ADJUST HOLD OPEN ANGLE  
 REGLEZ L' ANGLE D' ARRÊT  
 AJUSTE ÁNGULO DE ABERTURA

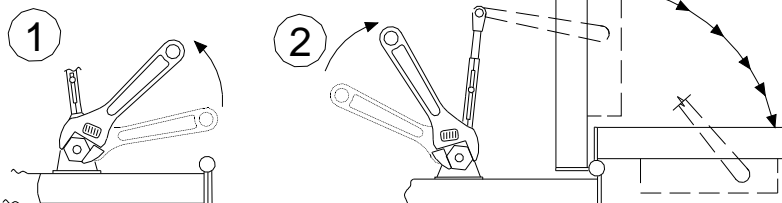

6.

ATTACH SHAFT COVER  
 FIXER COUVERCLE D'AXE  
 CONECTE LA CUBIERTA DE PINON

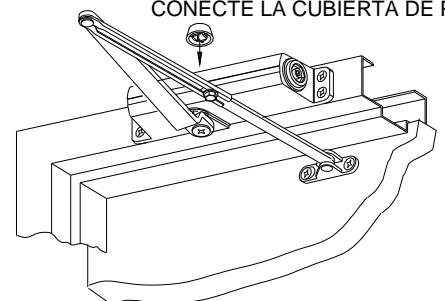

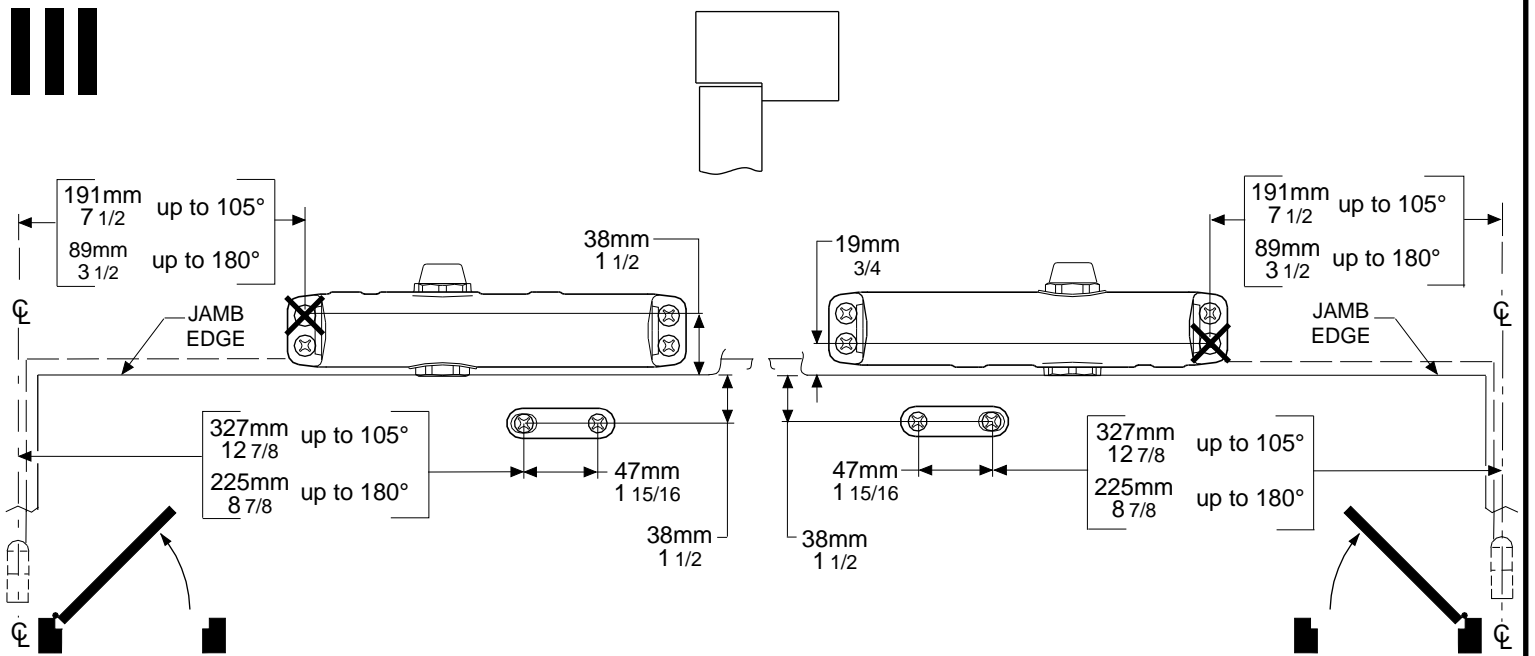

**1.**

|                   |     |
|-------------------|-----|
|                   |     |
| 750mm -           | - 8 |
| 850mm (32" - 34") | - 4 |
| 950mm (36")       | 0   |

**2.** MOUNT DOOR CLOSER / ROD & SHOE  
 MONTAGE DU FERME-PORTE / BRAS SECONDAIRE  
 MONTE EL CIERRA PUERTA / EL ZAPATO

**HOLD-OPEN OPTION**  
**OPTION BRAS D'ARRÊT**  
**OPCIÓN MANTENER ABIERTA**

**3.** ATTACH ARM, AS SHOWN  
 FIXER LE BRAS, TEL QU'INDIQUÉ  
 CONECTE EL BRAZO, COMO SE MUESTRA

**4.** ATTACH ARM AND ROD & SHOE  
 LIAISON BRAS PRINCIPAL ET SECONDAIRE  
 ENSEMBLE EL BRAZO CON LA VARILLA Y ZAPATO

**PRE-LOAD ARM**  
**REGLER LE BRAS**  
**PRE-CARGUE EL BRAZO**

**5.** HOLD-OPEN OPTION  
 OPTION BRAS D'ARRÊT  
 OPCIÓN MANTENER ABIERTA

ADJUST HOLD OPEN ANGLE  
 REGLEZ L' ANGLE D' ARRÊT  
 AJUSTE ÁNGULO DE ABERTURA

**6.** ATTACH SHAFT COVER  
 FIXER COUVERCLE D'AXE  
 CONECTE LA CUBIERTA DE PINON

# IV

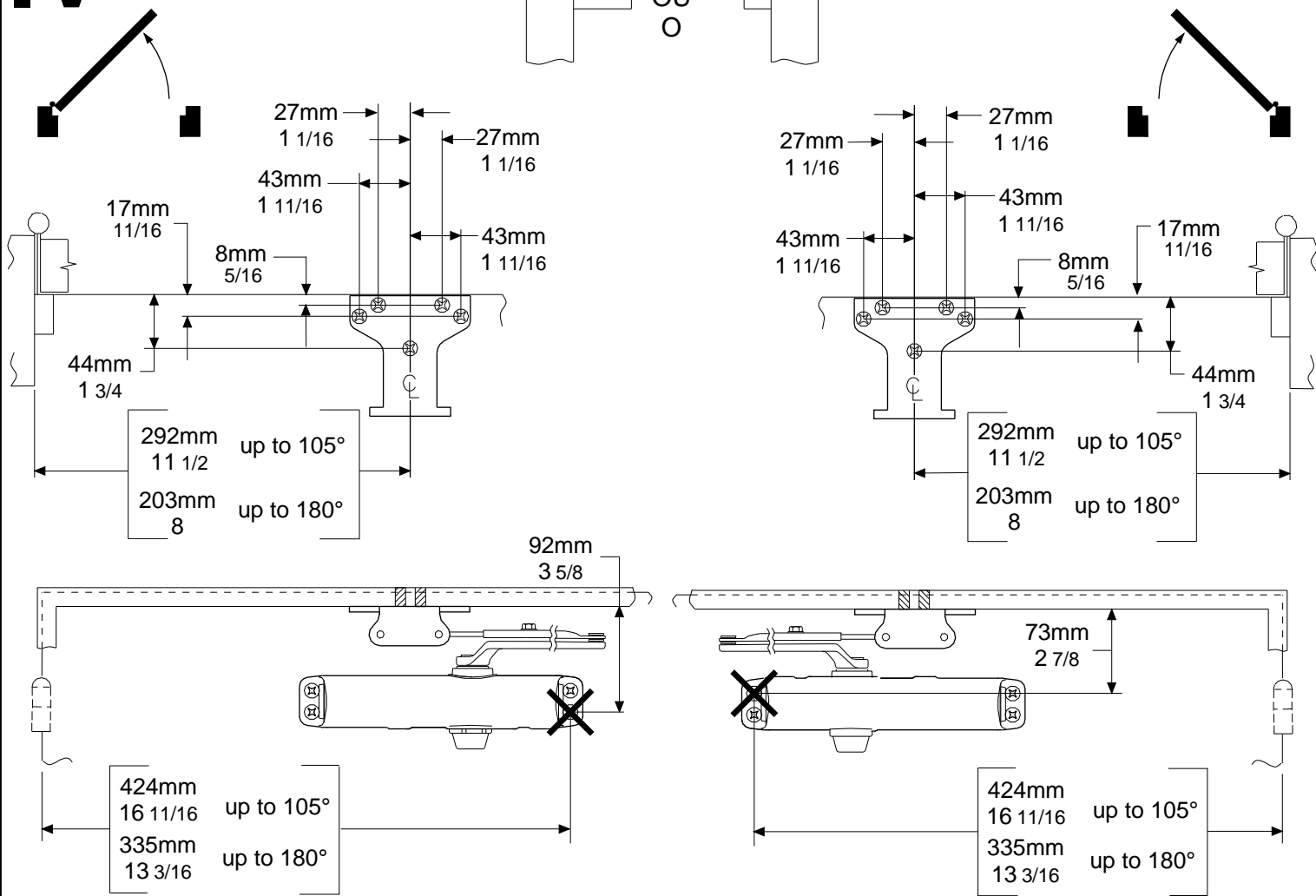
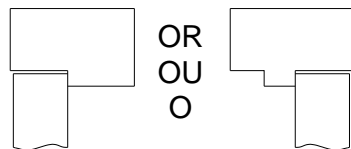

## 1.

|                 |     |
|-----------------|-----|
|                 |     |
| 750mm -         | - 8 |
| 850mm (32"-34") | - 4 |
| 950mm (36")     | 0   |

## 2.

MOUNT DOOR CLOSER  
MONTAGE DU FERME-PORTE  
MONTE EL CIERRA PUERTA

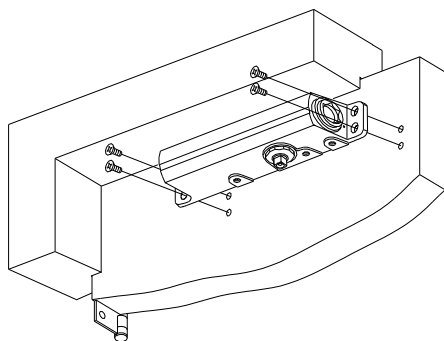

## 3.

ATTACH SHOE TO STOP  
ATTACHER LA SABOT  
CONECTE LA ZAPATA AL TRAVESAÑO

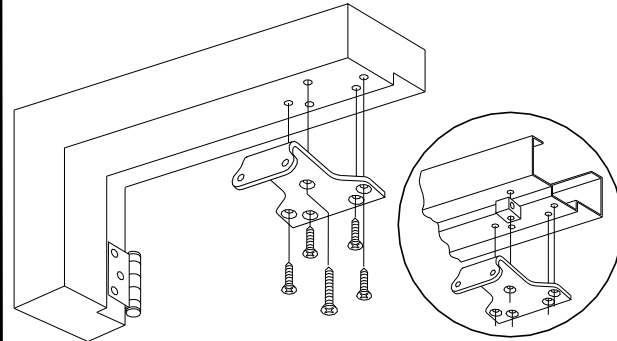

## 4.

PRE-LOAD FOR ARM  
REGLER LE BRAS  
PRE-CARGUE PARA EL BRAZO

1

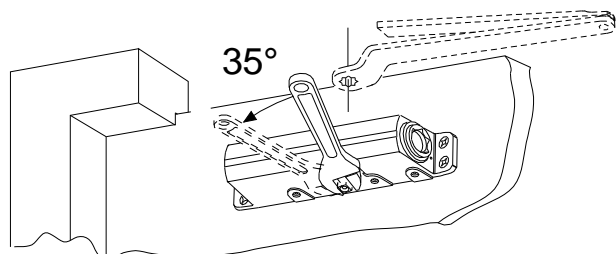

2

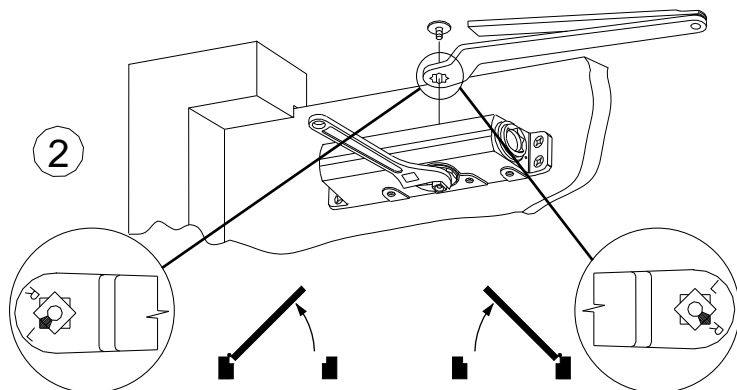

# IV

- 5.** ATTACH ROD & SHOE TO SHOE BRACKET  
FIXER LA PATTE SUR LA PLAQUE  
ENSAMBLE LA ZAPATA CON LA VARILLA  
Y ZAPATA DEL BRAZO

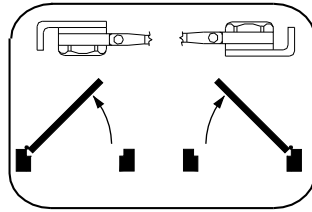
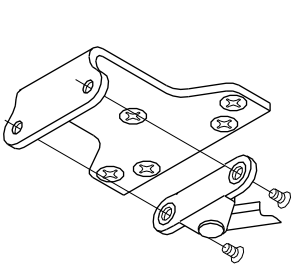

HOLD-OPEN OPTION  
OPTION BRAS D' ARRÊT  
OPCION MANTENER ABIERTA

- 6.** ATTACH ARM AND ROD & SHOE  
LIAISON BRAS PRINCIPAL ET SECONDAIRE  
ENSAMBLE EL BRAZO CON LA VARILLA Y ZAPATA

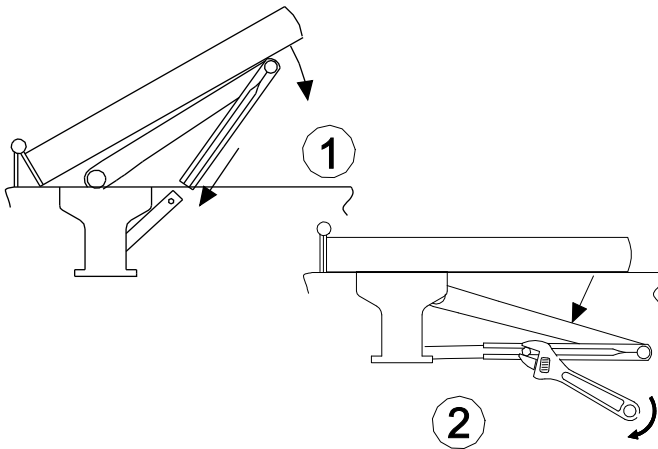

- 7.** HOLD-OPEN OPTION  
OPTION BRAS D' ARRÊT  
OPCION MANTENER ABIERTA

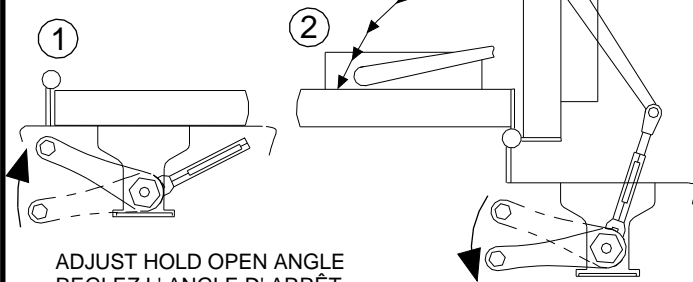

ADJUST HOLD OPEN ANGLE  
REGLEZ L' ANGLE D' ARRÊT  
AJUSTE ÁNGULO DE ABERTURA

- 8.** ATTACH SHAFT COVER  
FIXER COUVERCLE D'AXE  
CONECTE LA CUBIERTA DE PINON

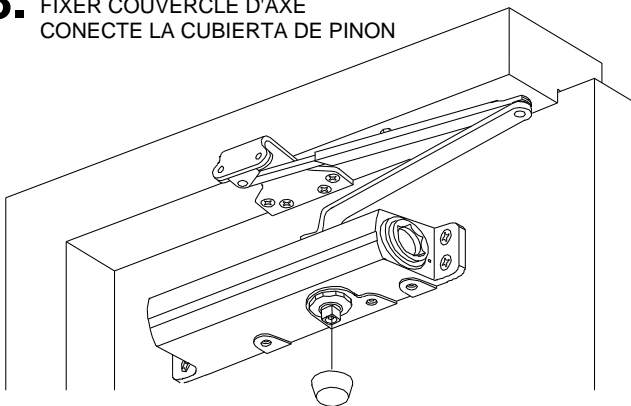

230mm  
9 1/16

19mm  
3/4

**IR LCN® 1070**

