

II. CONFIGURING THE INHIBITION INPUT

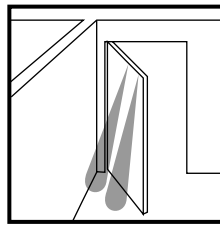

- The inhibition input is used to stop the detection process when the door must face a fixed obstacle at the end of its swing angle.
- Adjust the operator «cam switch». Cable the inhibition input to inhibit the sensor before detecting the obstacle.

III. ANTI-MASKING TEST

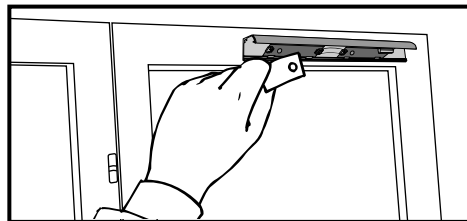

- The sensor is open (without front cover).
- The anti-masking function is activated (see : adjustment of the functions) both in MASTER and SLAVES.
- Make sure there is no target in front of the sensor.
- Place the hole of the test paper in front of the reception lens of each module.
- The red LED does not light up, otherwise the configuration must not be used for this type of environment.

MONITORED VERSION

FOR MONITORED VERSION ONLY :

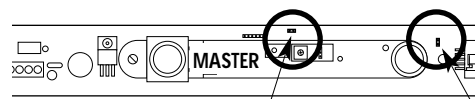

SURVEILLANCE CANCELLATION JUMPER

END-OF-LOOP JUMPER

- Inputs 1 and 2 of the terminal are properly wired and supplied.
- The end-of-loop jumper is mounted on the last SLAVE or MASTER module, if there are no SLAVES.
- If the surveillance option can not be used, move the end-of-loop jumper on the surveillance cancellation jumper. Terminals 1 and 2 are then unnecessary.

END OF INSTALLATION

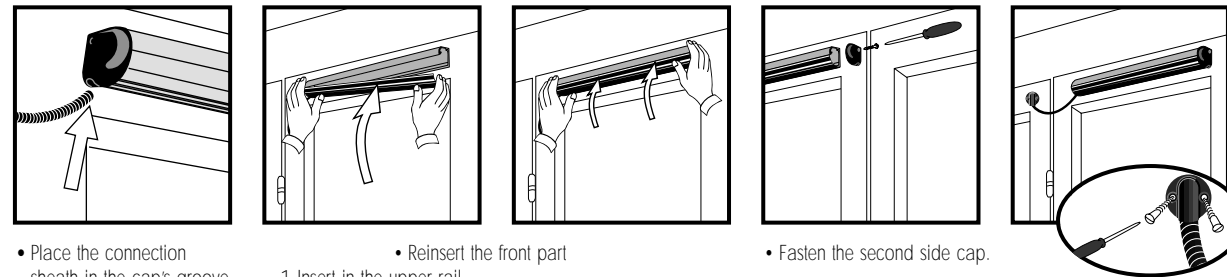

- Place the connection sheath in the cap's groove.
- Reinsert the front part
 1. Insert in the upper rail.
 2. Tighten the front part progressively.
- Fasten the second side cap.
- Screw the wall fixation fastener onto the fixed box, inserting the connection sheath in it.

TROUBLESHOOTING

SYMPTOMS :	CORRECTIVE ACTIONS :
The door does not open. The red LED does not light up in the absence of a target.	a) Check power supply. b) Check relay cabling (NO or NC).
The door does not open. The red LED lights up.	a) Check that the surveillance input is deactivated. b) Decrease the detection distance.
The detector detects erratically.	a) Make another antimasking test. b) Decrease detection distance.
You have problems inserting the module into the aluminium section.	Check the module orientation.
The door opens without taking detection into account. The red LED lights up.	Check relay cabling.

WARNING : this sensor is designed exclusively to make automatic doors safer.



We open up New Horizons

EYE-TECH USER'S GUIDE

SAFETY SENSOR FOR SWINGING DOORS AND REVOLVING DOORS

TECHNICAL CHARACTERISTICS

Technology	: Active Infrared • 1 master module • 9 slave modules (standard version) • 8 slave modules (monitored version)	Standard output	: Switch-over relay (voltage free contact) • relay contact ratings (max voltage): 60 V DC / 125 V AC • relay contact ratings (max current): 1 A (resistive) • max. switching power: 30 W (DC) / 60 VA (AC)
Detection distance	: 0.7 m to 2.5 m (adjustable by linear movement swivelling cam)	Optional output	: Open collector transistor • max. voltage: 30 V DC • max. current: 100 mA (protection against short-circuits)
Module inclination angle	: 0° - 5° - 10° - 15° - 20° - 25°	Output holding time	: 0.1 s to 4.5 s (adjustable)
Diameter of the infrared beam at 2 m	: 0.13 m	Adjustments	: • detection distance (by swivelling cam) • holding time (by potentiometer) • normal/antimasking configuration (by jumper) • dark ON/light ON configuration (by jumper)
Detection mode	: Presence (and movement)	Temperature range	: -20°C to +50°C
Detection duration (presence)	: Infinite	Immunity	: Electromagnetic compatibility (EMC) 89/336/EEC and 92/31/EEC
Response time	: < 50 ms	Dimensions	: 340 - 700 - 900 mm (L) x 43.5 mm (H) x 47.5 mm (D)
Special inputs	: • system inhibition • optional : surveillance	Mass	: • 0.330 Kg (length 340 mm, 1 Master) • 0.620 Kg (length 700 mm, 1 Master + 1 Slave) • 0.740 Kg (length 900 mm, 1 Master + 2 Slaves)
Supply voltage	: 12 to 24 V AC/DC ±10%	Material	: Aluminium, ABS and Plexiglas
• relay output option	: 12 to 30 V DC ±10%	Colour of the box	: Natural aluminium (black or chrome optional) black front side
• transistor output option	: 50 to 60 Hz	Connection sheath	: 0.5 m
Mains frequency			
Power consumption			
• Master ON	: 60 mA maximum		
• Slave ON	: 40 mA maximum		
• Master OFF	: 30 mA maximum		
• Slave OFF	: 30 mA maximum		

DESCRIPTION OF THE SENSOR

OVER VIEW

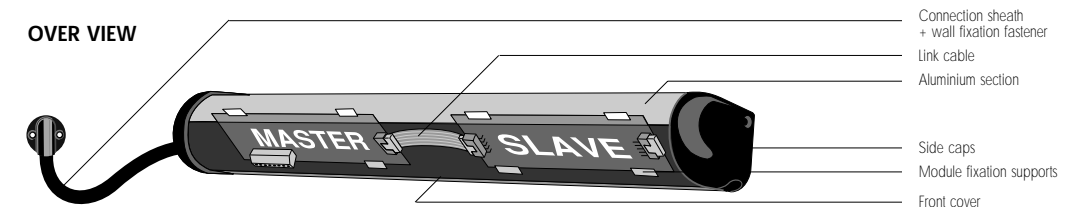

MASTER MODULE

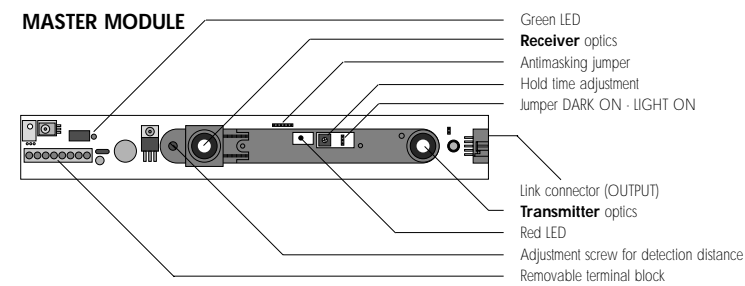

SLAVE MODULE

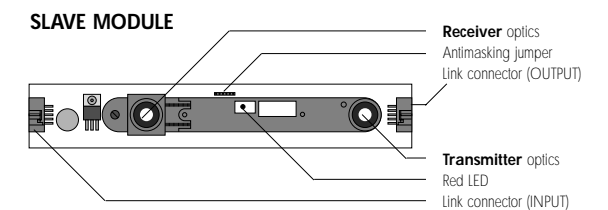

TIPS FOR USE

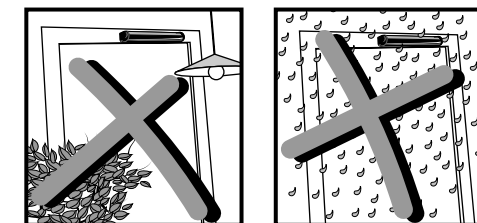

- No objects shall be within the detection zone.
- Preferably, exposure to heavy rain must be avoided.

OPENING AND DISASSEMBLY OF THE SENSOR

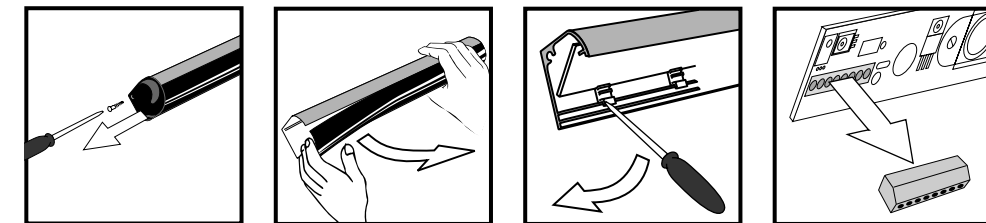

- Unscrew side caps.
- Remove the front cover by one of the sides.
- Remove the plastic module supports using a screwdriver after disconnecting the SLAVES.
- Remove the MASTER's removable terminal block.

DISASSEMBLED MATERIAL



FUNCTION ADJUSTMENT AND CONFIGURATION

Each module (MASTER and SLAVE) is equipped with jumpers allowing configuration.	INITIAL ADJUSTMENT		
MASTER + SLAVE Anti-masking function <i>The sensor is put in detection mode when one of the optics is masked.</i>	NOT ACTIVATED	ACTIVATED 	NOT ACTIVATED
MASTER Operating mode <i>DO : the relay is released on detection LO : the relay is activated on detection</i>	DARK-ON	DARK ON 	LIGHT ON
MASTER Holding time potentiometer <i>Increased holding time.</i>	0,1 s		
FOR CONTROLLED VERSION End-of-loop jumper to be placed on the last slave of the link (or on the MASTER if no SLAVES).	Jumper supplied with the master	MASTER :	SLAVE :

FIXING THE PROFILE ON THE LEAF

I. INITIAL STEPS

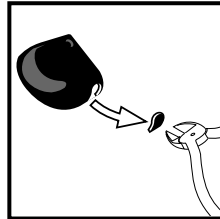

- Break the part of the cap (hinge side) to allow passage for the connection sheath.

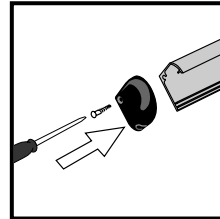

- Screw the cap on the section from the door hinge side.

II. INSTALLATION ON SWINGING DOORS AND REVOLVING DOORS

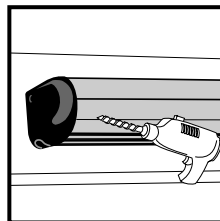

- Drill two holes in the back of the aluminium section and in the door leaf. (Use the groove to position the holes).

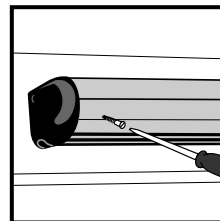

- Screw the fixing screws.
WARNING : do not position the screws in the same place as card fixing support.

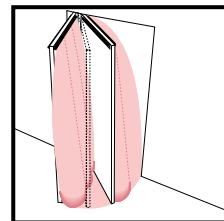

- Example of use on swinging doors.

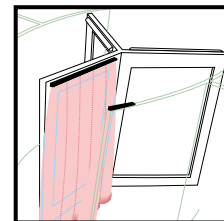

- Example of use on revolving doors.

III. APPLICATION TO INCREASE SAFETY OF SLIDING DOORS OR SPECIAL USES

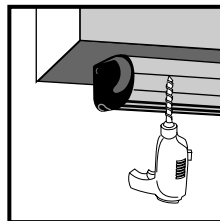

- Drill two holes in the upper part of the section.

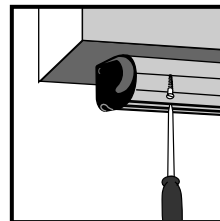

- Screw the screws.

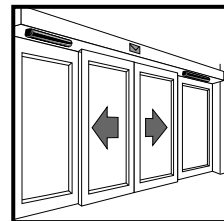

- Example of use on a sliding door.

ORIENTATION OF THE MODULES

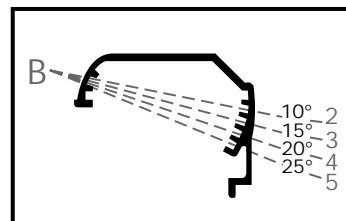
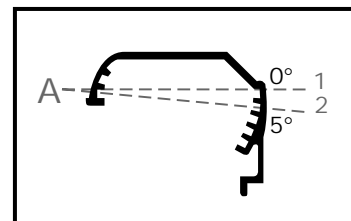

Choose the position of modules in the housings from the available positions described above. Recommended angle : 20°.

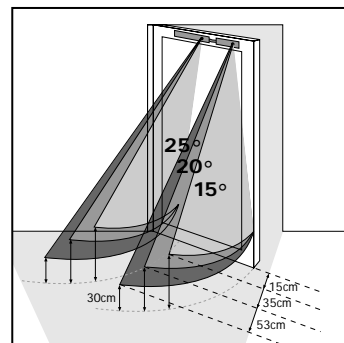

Overview of the sensing fields as a function of module placement angles.

INSERTING AND CONNECTING THE MODULES

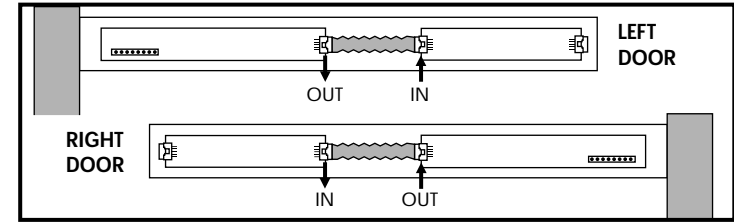
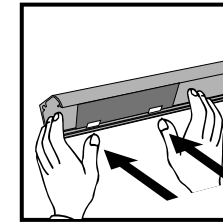
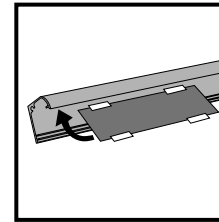

- Reinsert the module(s) and make sure that the MASTER is on the hinge side.

- connect the different modules together.

WARNING : make sure that an input is connected to an output.

REMARK : place the last SLAVE module (or the single MASTER) as close as possible from the sharp edge of the door.

PREPARING THE CONNECTION CABLE

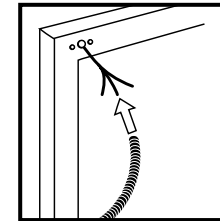
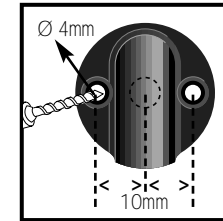
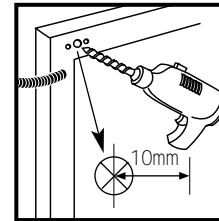

- Drill a hole in the fixed part of the door for the passage of wires.
- Drill two 4 mm holes on each side of the hole for the passage of the wires (to fix the wall fixation fastener).

- Pass the wire through the connection sheath.
- Connect to the removable terminal strip of the MASTER.

CABLING THE SENSOR

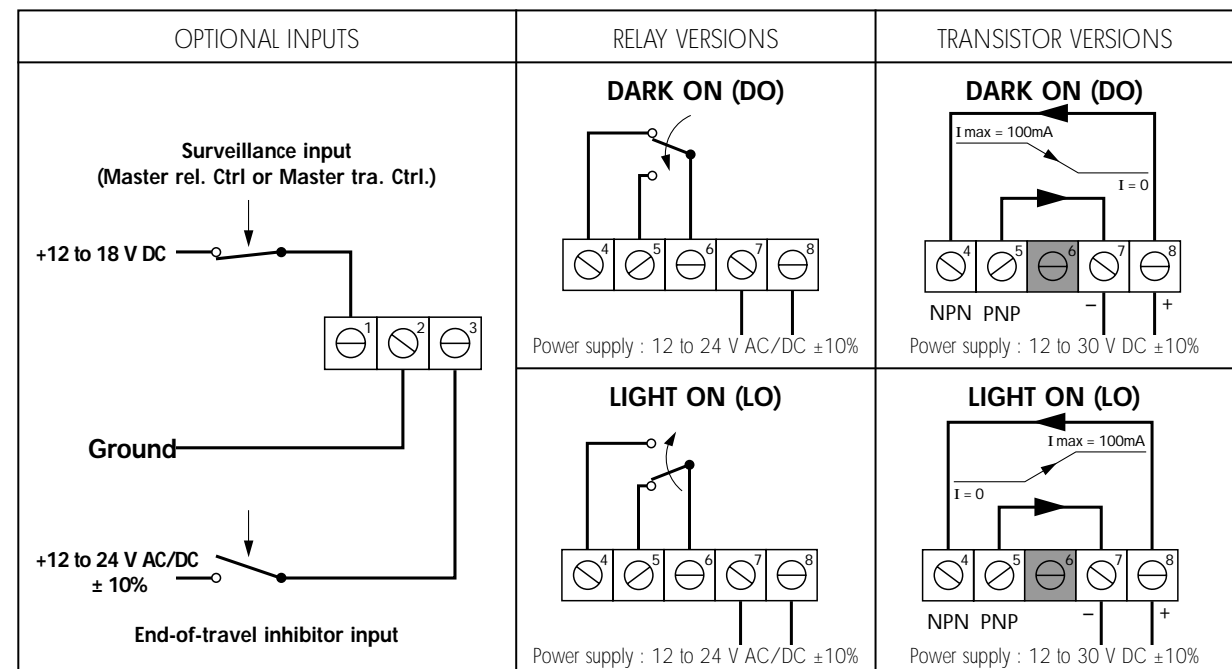

REMARK : If an inductive load is connected (operator relay), put a protective diode.

SENSOR TEST

I. DETECTION DISTANCE ADJUSTMENT :

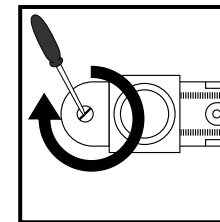
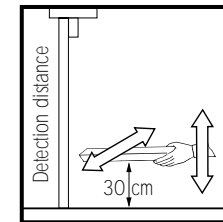

- Take the cardboard box of the EYE-TECH.
- Adjust the holding time potentiometer of the input to its minimum value.
- Place the box at 30 cm from the floor and at a distance from the door determined by the module inclination angle.
- Move the box up and down and from left to right to estimate the dead zone.

- Using a screwdriver, rotate the distance detection adjustment screw to obtain the detection at ±30 cm (and vice versa).
- Clockwise rotation by one notch increases the detection distance by ±10 cm (and inversely).

- Force the door to open.
- If detection is observed in the absence of an obstacle, rotate the screw counterclockwise.

- When the adjustment is correct, set the holding potentiometer to the desired value (recommended value : 2s).