



Relcross Ltd, Hambleton Avenue, Devizes, Wiltshire, SN10 2RT
Tel: 01380 729 600 Fax:01380 729 888
Web: www.relcross.co.uk E-mail: sales@relcross.co.uk

New Enhanced Power Supplies

PS0 EL BB II – 24 V DC - 3.0 Amp Installation Instructions

INSTALLATION WARNING – This equipment **MUST BE EARTHED**

The enclosure must be fixed to a vertical flat surface at a maximum ambient temperature of 45 degrees C in a well ventilated area. This power supply must be installed in accordance with the current IEE regulations covering low voltage power supplies complying with the low voltage directive SI 1994 No 3260 73/23/EEC (LVD)

Features:

- Two stage current protection.
- Short circuit protection.
- Thermal overload protection.
- Constant voltage regulation.
- Mains failure or low battery voltage warning, user selectable
- Fire relay interface to fire alarm system.
- Enclosure door 3 LED status indicators.
- PCB mounted engineering status LED indicators, show:
 - Over current
 - Fire alarm relay status
- Battery management electronics providing:
 - Low voltage trip to disconnect battery and extend battery life.
 - Reverse battery polarity protection.

Description:

The Von Duprin device is supplied with unregulated DC at the correct voltage of 24 volts. A separate regulated circuit charges batteries (if fitted) at the correct float voltage of 27.6 V DC

First stage current protection

If the load exceeds the power supply current rating, an electronic sensor detects this overload and folds the voltage back to 23.0 volts and provides current limiting, this is indicated by the red overload LED on the circuit board. **Second stage current protection:** A short circuit or severe overload will shut down the regulator & output voltage will be zero until the fault is removed.

Battery management, if battery fitted

Under normal conditions, the battery floats at 27.6 Volts. If the mains power fails, the battery takes the load. Eventually the voltage will drop to 21 volts & a relay disconnects the battery, this is automatically reset once the mains has been re-energised. This feature extends battery life by preventing deep discharging and prevents equipment malfunction.

User selectable voltage free relay warning - terminals WC WNO WNC rated 1 Amp

The electronic voltage detection circuit is configured by selecting a link switch on the PCB. The relay will trigger as set: **FR** – Fire relay **MF** - Mains failure or **LB** - Low battery 23.0 volts .

Fire control relay – terminals +NO & +NC rated 15 Amps (breaking)

Terminals FR & FR (Fire relay) can be connected to a voltage free fire system and or access control system. Relay operation is indicated via the external yellow LED. If the fire relay is used, the positive supply is from either +NC (normally closed) and/or +NO (normally open) depending on desired relay operation.

Cabinet dimensions in mm: 325H * 255W * 90D



New Enhanced Power Supplies

Commissioning tests

Initial installation test

Prerequisites:

- Disconnect battery – if supplied with battery
- Disconnect all supplied equipment
- Place the handbag link to LB low battery (on PCB).

Test procedure

Switch on mains power; the following indicators should be illuminated:

- Red and Green – on the front panel
- Green on the PCB

Fire alarm relay

Switch off mains power & connect a link between terminals FR & FR

Switch on mains power – the yellow LED on front panel should now be lit,

Connect a meter between terminals 0V & +NO - this should be live at PSU output voltage

Switch off mains power & remove the link between terminals FR & FR, switch on mains power and connect a meter between terminals 0V & +NO which should be live at PSU output voltage. Observe LEDs switch off in the following sequence: Red then green on PCB then green on front panel last

Battery functionality – optional if fitted

Switch off mains power & connect the battery, place handbag link to MF (mains failure) switch on mains power, then switch off. The power supply is now running on the battery, note the green LED on PCB will be off but the green LED on the front panel will be on. The relay contacts WNO to WNC will change over

Tests with the load connected – battery not connected (if supplied): With the load connected, switch on the mains. The following LEDs should be on: red & green on front panel, green on PCB and yellow if using relay FR, this indicates the test & the power supply loading is correct.

If only the red LED is illuminated there is a short circuit with the load connected. If red, & green on the front panel with green and red (over load) on the PCB illuminated the connected load has exceeded the power supply rated output & must be reduced.

Front panel LED	PCB LED	Means
Red + Green	None	Normal operation
Red + Green + Yellow	None	Normal operation with fire relay energised
Green	Green if MFW *	Power supply on battery
Green + Yellow	Green if MFW *	Power supply on battery with fire relay energised
Red only	None	Dead short on output
Red + Green	Red	Current rating exceeded

* MFW – mains failure warning if configured



New Enhanced Power Supplies

Battery connection, Please note batteries must be used for 2 or 3 point devices

With the power supply switched off, connect the two 7A/hr batteries in series to provide 24 V DC using the black interconnect lead as shown below:

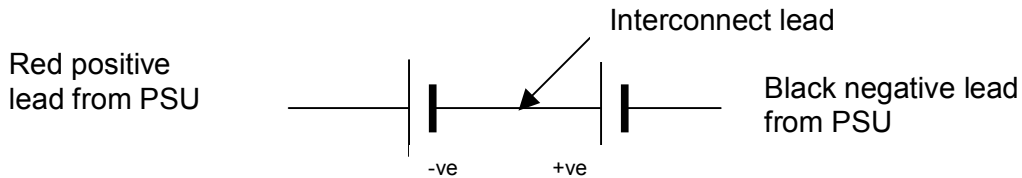

Von Duprin connection

The Von Duprin device is not polarity sensitive, it needs to be supplied from 0V & +NS or may be connected to 0V & either +NO or +NC for fire alarm switching – please consult for local fire alarm switching requirements. Ensure the device is connected with cable capable of carrying the initial surge current of 16 Amps. An additional relay is provided to switch the device & a sample wiring diagram is shown on next page.

Other connections on PSU

Please note:

- The fire alarm connection is now voltage free
- For fire alarm relay connection, connect volt free contacts FR & FR to normally open fire alarm relay contact see diagram below
- Positive and negative (non switched) supplied from +NS & 0V

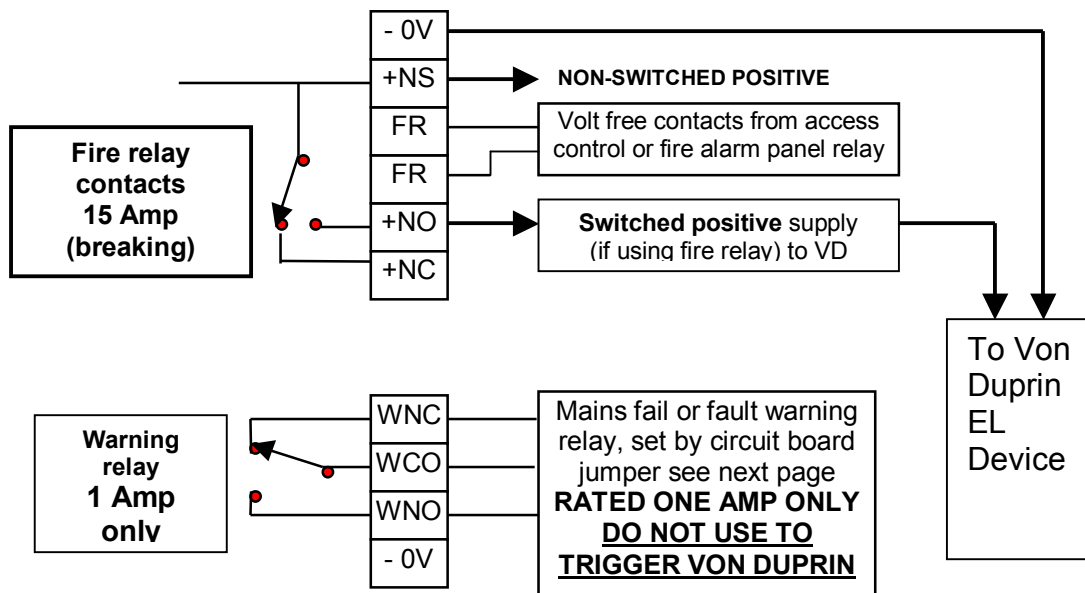

Relays shown in de-energised state



New Enhanced Power Supplies

Von Duprin device (PS0 EL BB)

The device is non polarity sensitive & requires a current of 16 Amps for 300ms to operate the latch electrically. The supply is not regulated and access control devices such as swipe card readers etc may require a separate supply.

Example connection diagram, access control triggers the relay thus energising the device. An optional connection to the fire alarm relay is shown so that the device is triggered in the event of a fire alarm. (N1) An optional connection shown from (+NO) to the positive supply of the relay would unlock the device in the event of a fire alarm.

This is a sample diagram only and actual installations may be different.

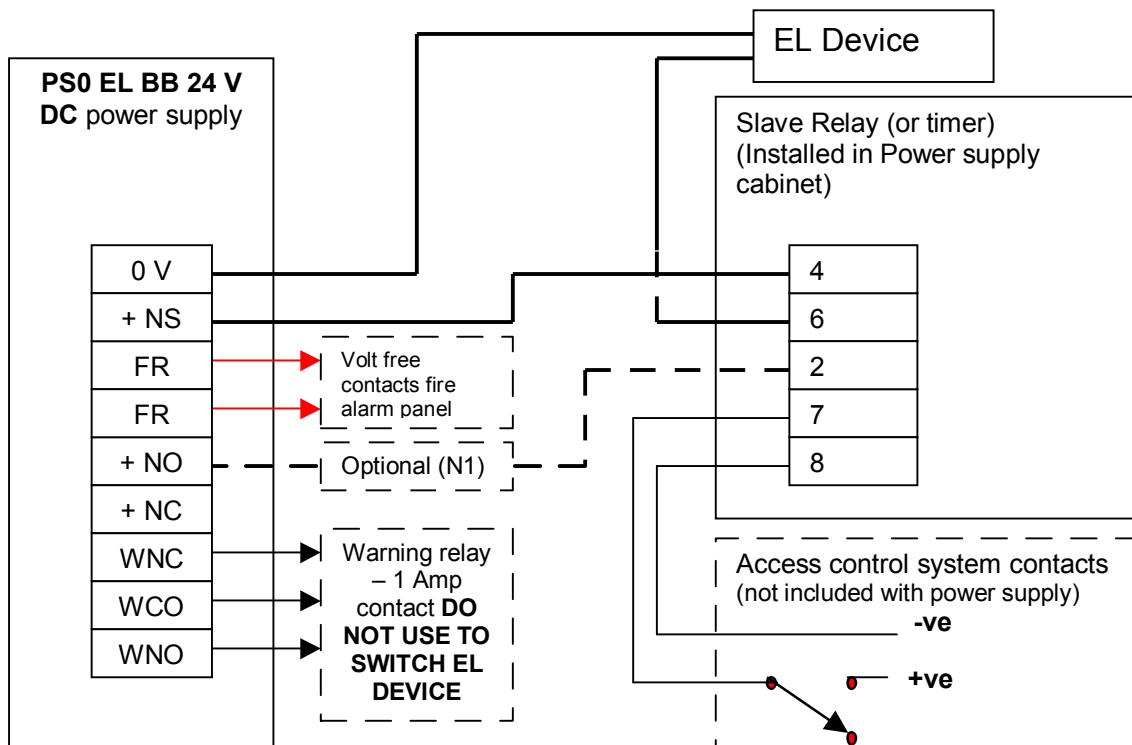

To configure the **warning relay** set the link (lower left on circuit board) in the appropriate position

MF – Mains failure
LB – Low battery - 23.0 V
FR – Fire relay

Example below shows link set to trigger warning relay on mains failure

MF LB FR

Relay pin out detail is shown >>

Connect one device per EL BB PSU

If your power supply has a timer separate instructions will be supplied for the timer & the relay will not be fitted

