

## DK 26 Controller & keypad specifications

### Features

- Designed for high volume use in controlling entry through electrically locked doors
- Lifetime replacement warranty
- Fully weather proof and water proof
- Constructed of investment cast stainless steel with individual EPDM rubber buttons
- The digital keypad system circuit board is a remote unit to allow for increased security
- Unit operates on 12 or 24 volts AC or DC Relcross PS01.N or PS02.N
- The digital keypad system circuit board is mounted in a metal enclosure and provides for multiple users.
- DP/DT relay output for lock control and alarm shunt, camera call up or other device interface as well as a REX input
- Power consumption at rest, 7mA @ 12VDC – 20mA @ 24VDC,
- Power consumption maximum is 160mA @ 12VDC – 190mA @ 24VDC
- Operating Temperature (CPU) 0 to 70C [32 to 158F] Keypad -30 to 70C [-22 to 158F]

### Options

- Expansion Circuit Board
- Wiegand output model **DK26W**

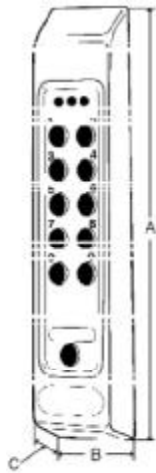

MODEL	A	B	C
DK-26			
KEYPAD	6.75	1.375	.875

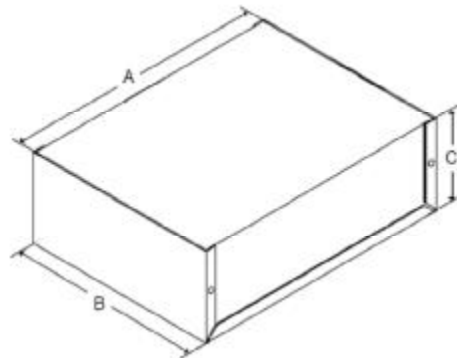

MODEL	A	B	C
DK-26			
CBO	8.25	6	3

- A. The digital keypad shall be produced by an ISO 9001 certified manufacturer.
- B. The digital keypad shall have a lifetime replacement warranty.
- C. The digital keypad shall be weather proof, vandal resistant, and suitable for mounting on a narrow mullion.
- D. The digital keypad housing shall be constructed of investment cast stainless steel with individual EPDM rubber buttons.
- E. The digital keypad system circuit board shall be a remote unit to allow for increased security and shall operate on 12 or 24 volts AC or DC.
- F. The digital keypad system circuit board shall be mounted in a metal enclosure and provide for multiple users.
- G. The digital keypad shall have a DP/DT relay output for lock control and alarm shunt, camera call up or other device interface as well as a REX input.
- H. Power consumption at rest shall not exceed 7mA @ 12VDC – 20mA @ 24VDC.
- I. Power consumption maximum shall not exceed 160mA @ 12VDC and 190mA @ 24 VDC.

### Digital Keypad System – Model 26W

- J. The digital keypad system circuit board shall interface with a PC based access system via Weigand output protocol.