

VON DUPRIN®

Installation Instructions

33/35A Series Rim Exit Device

Devices covered by these instructions:

- 33/35A Rim Exit Device
- CD33/35A Rim Exit Device
- EL33/35A Rim Exit Device
- SS33/35A Rim Exit Device

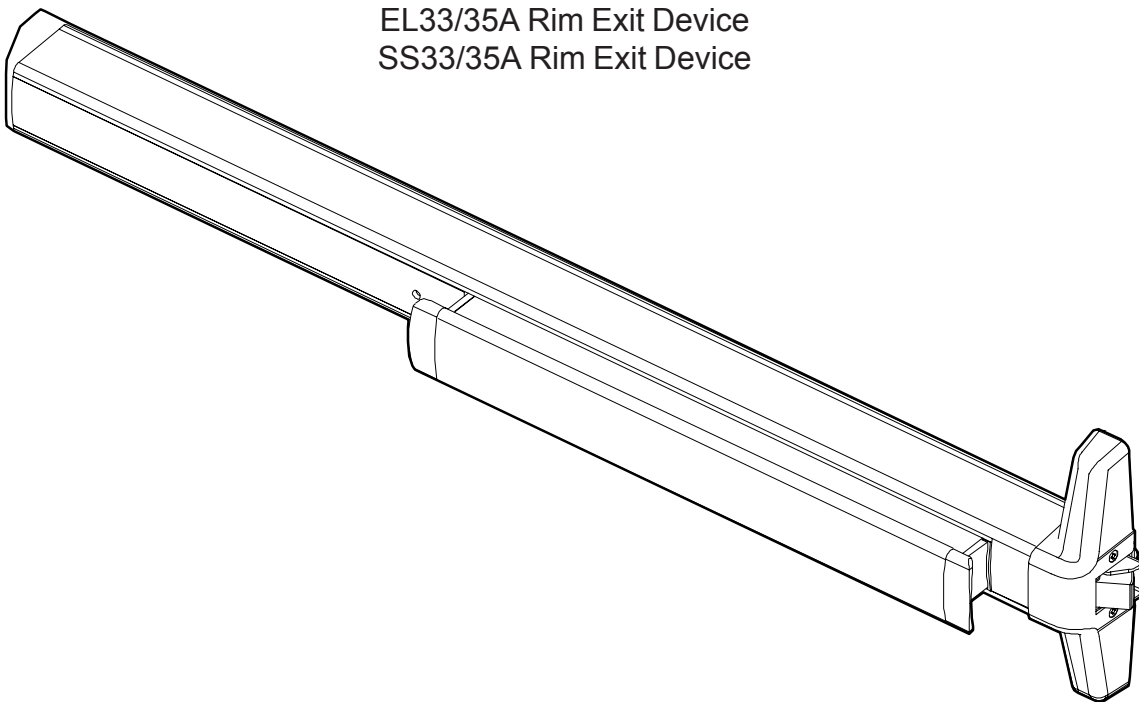

Please give these instructions to building owner after device is installed

Special tools needed:

- 5/64" hex wrench
- #10-24 tap
- Drill bits: #25, 1/8", 1/4",
5/16", 13/32"

Index:

- Screw chart 2
- Device installation 3-5
- Optional equipment 6-7
- Strike preparation 9-10
- Template 11-12

This product is covered by the following patent numbers:

3,767,238 4,167,280
3,854,763 4,466,643



SCREW CHART

A

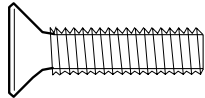
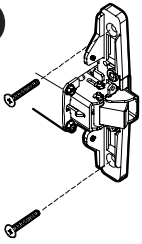

1/4-20 x 1" _____

Trim mount or sex bolts:
(1-3/4" door)

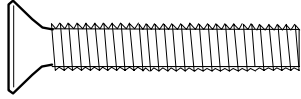

1/4-20 x 1-1/2" _____

(2-1/4" door)

B

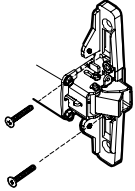

#10-24 X 1" _____

Metal door surface mount
(Yellow)

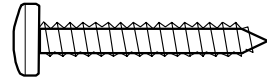

#10 X 1-1/4" _____

Wood door surface mount

C

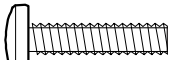
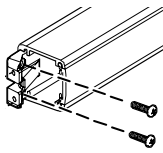

#10-24 X 3/4" _____

Surface mount or
Sex bolts 1-3/4" door (silver)

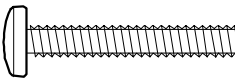

#10-24 X 1-1/8" _____

Sex bolts 2-1/4" door (silver)

D

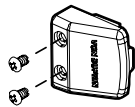

#10-16 X 3/8" Thread cutting _____

End cap

E

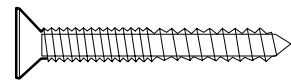
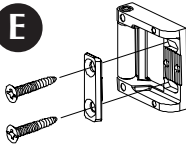

#10-12 x 10-24 x 1-1/4" combination _____

Metal or wood frame

F

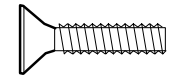
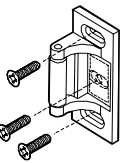

#10-24 X 3/4" _____

Metal frame

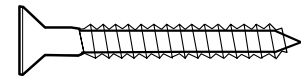

#10 X 1-1/2" Wood screw _____

Wood frame

G

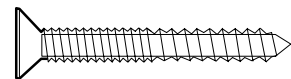
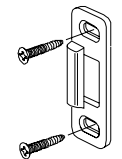

#10-12 x 10-24 x 1-1/4" combination _____

Metal or wood frame

H

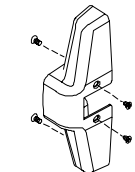

#8-18 x 3/8" thread cutting _____

Center case cover

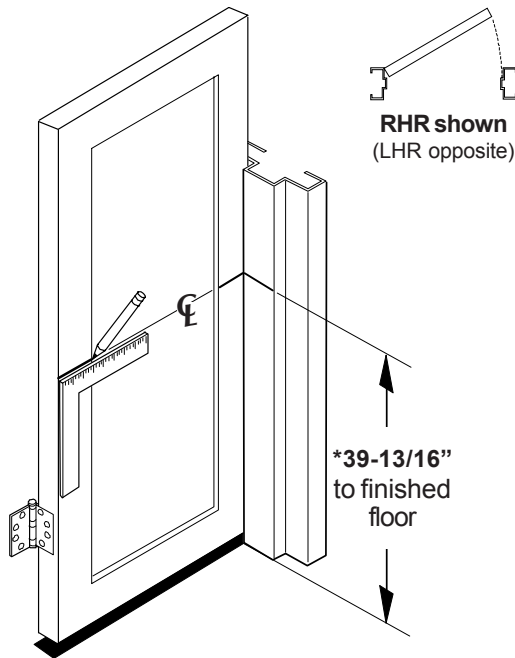
1**Draw device center line (☉) on door and frame as shown.**

*For double doors with a mullion and strike already installed, use existing strike center line.

2**Prepare frame for strike using paper templates.**

See pages 9 and 10 for strike templates and frame preparation dimensions.

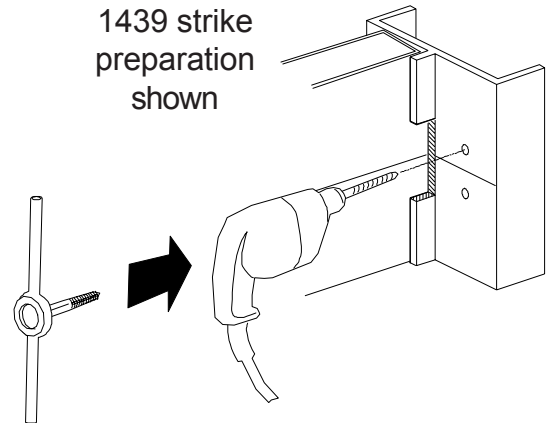
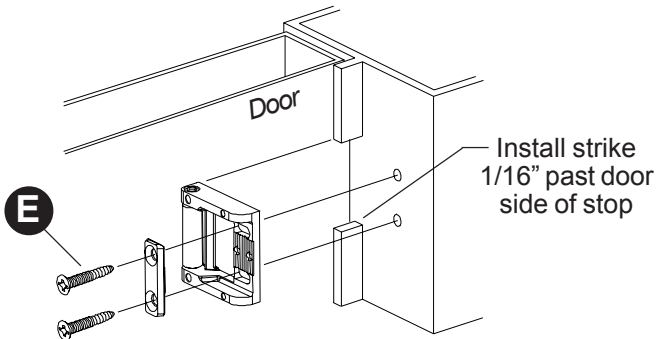
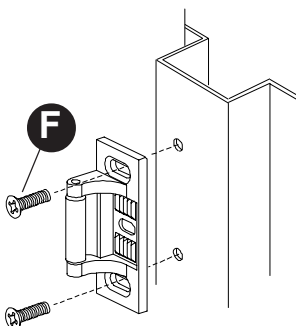
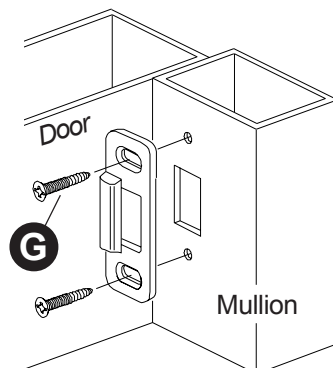
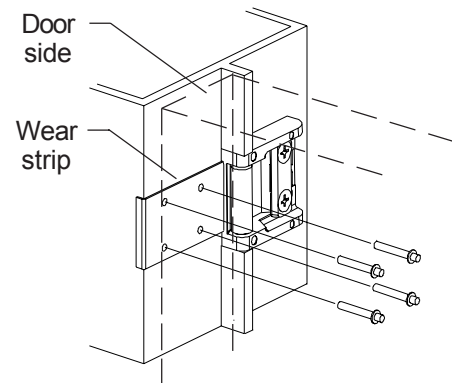
**3****Install strike using two screws only at this time.****1439 Strike (standard)****299 Strike****1606 Strike****4****If using a 1439 strike, install wear strip. If not, go to step 5.**

- A. Center wear strip on strike as shown.
- B. Mark and drill 1/8" dia. holes (4 places).
- C. Install wear strip with flat head drive rivets (4 places) from 1439 strike package.

5

Tape template to door and mark door.

Paper Template (pages 11 and 12)

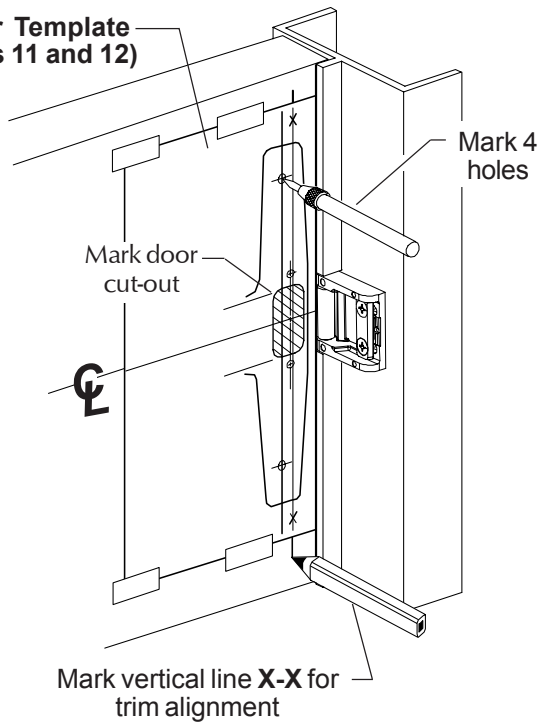

6

Prepare lock side of door for device and trim.

See trim instructions for pull side door preparation.

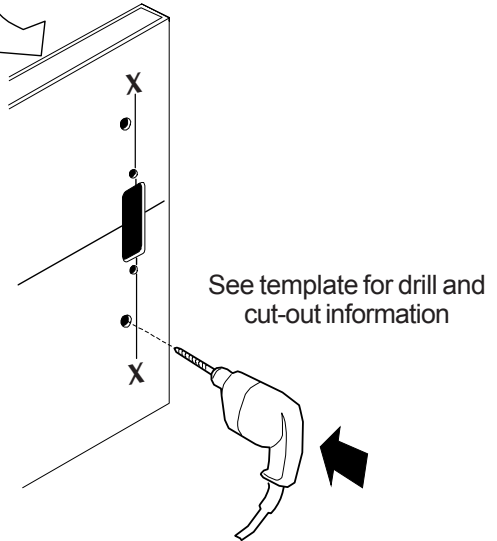

7

Measure to determine length to cut device.

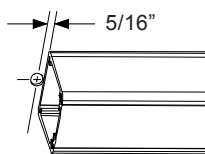
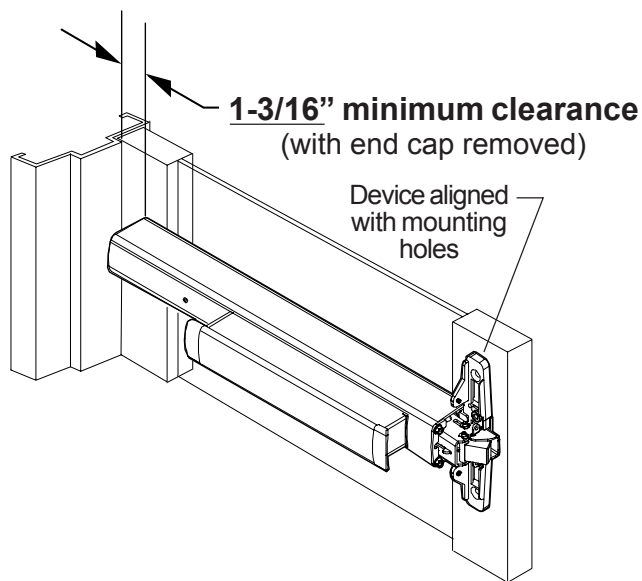

Note

If 5/8" diameter wire access hole has been predrilled in door, cut device 5/16" from center of hole.

8

Cut device to length.

Prepare device for cutting

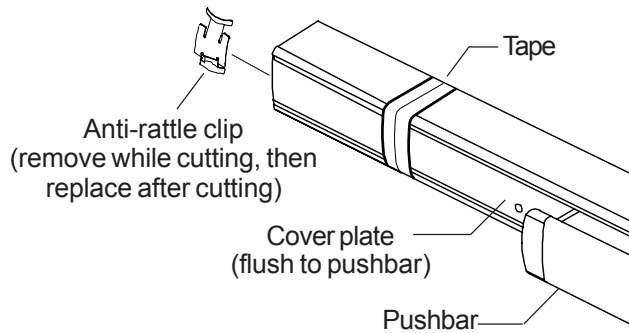

Cut device square

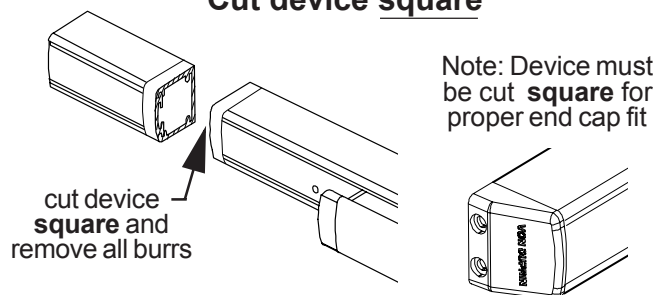

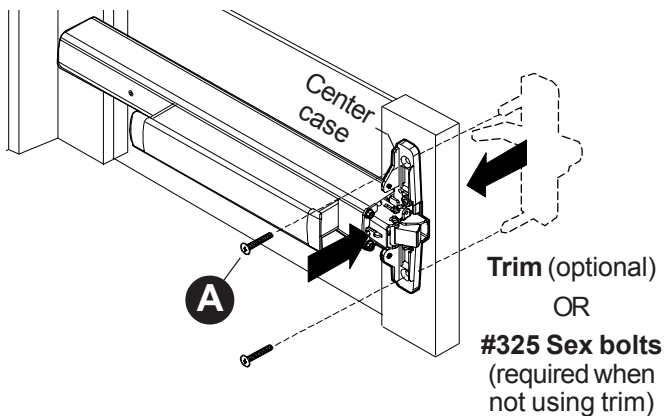
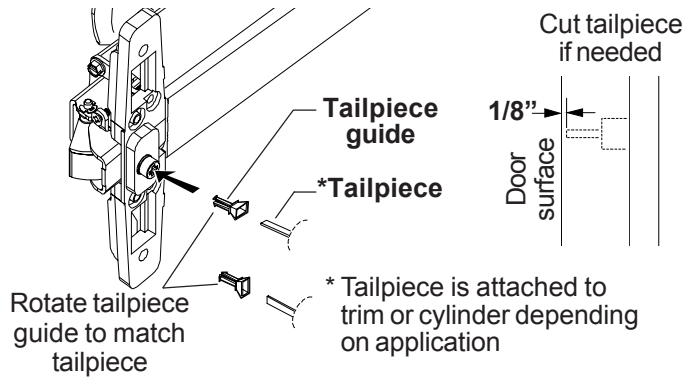
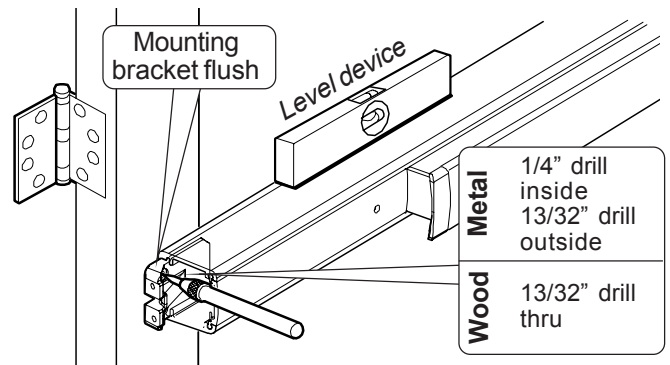
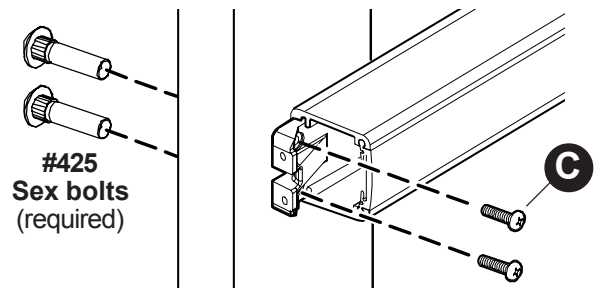
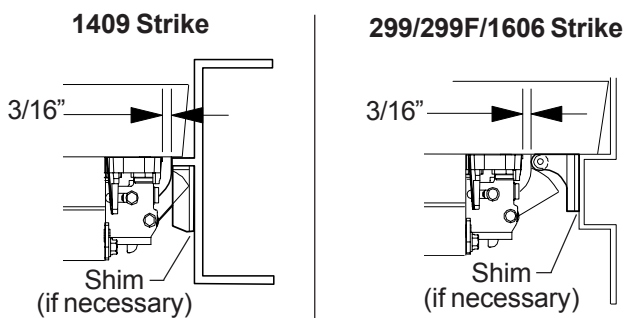
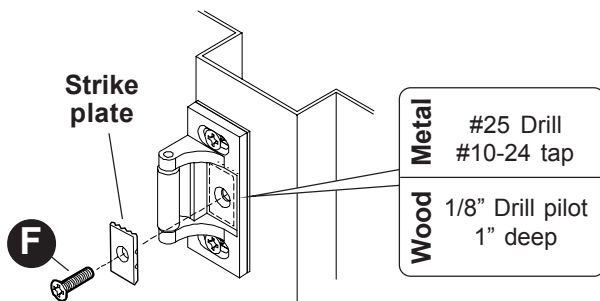
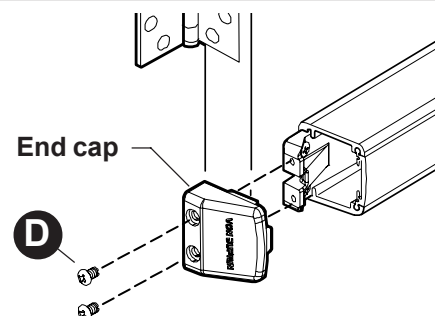
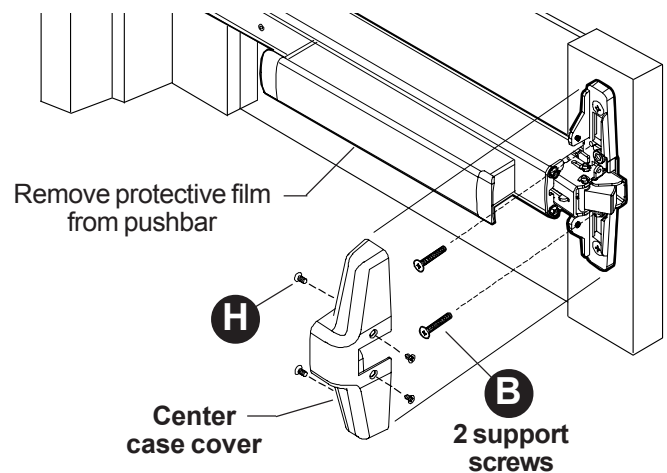
9**Install trim (if using) and secure device center case to door.****10****Install hinge stile mounting bracket.****Mark and prepare 2 mounting holes****Secure mounting bracket****11****Adjust strike with shim (if necessary) and secure strike.****Shim strike for 3/16" clearance to chassis****299 - Add plate and middle screw****12****Install 2 support screws, center case cover, and end cap.**

OPTIONAL EQUIPMENT

CD (CYLINDER DOGGING)

1. Remove mortise cylinder cam and reinstall in reverse (Figure 1).
2. Insert key and rotate cam to install the cylinder to the cover plate (Figure 2).
3. Remove key to slide cover plate in position in the mechanism case.

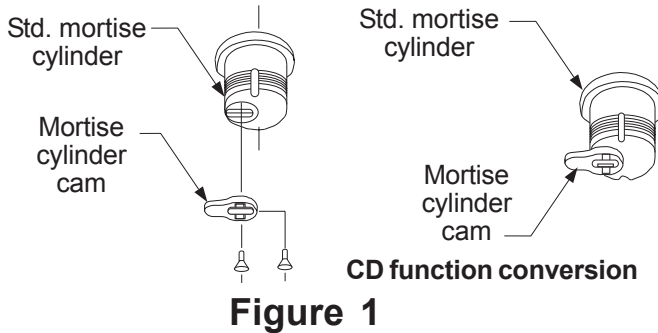

Dogging procedure

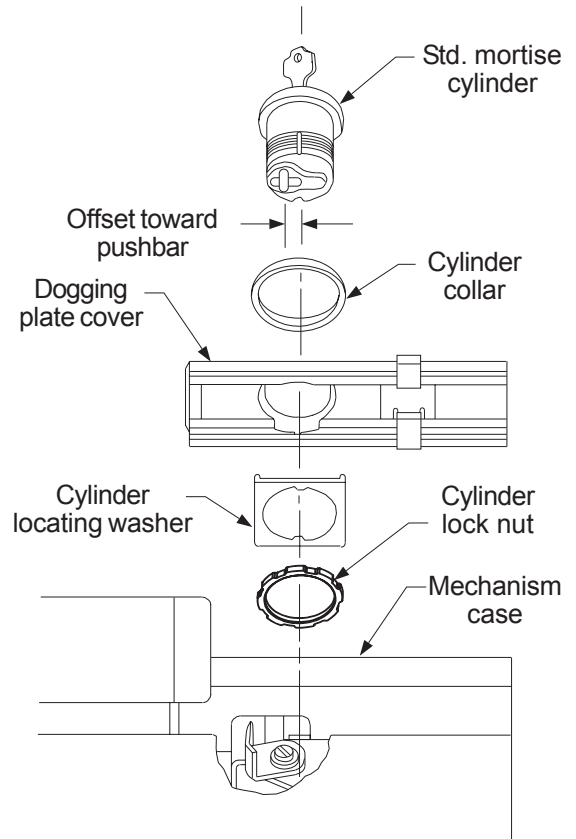
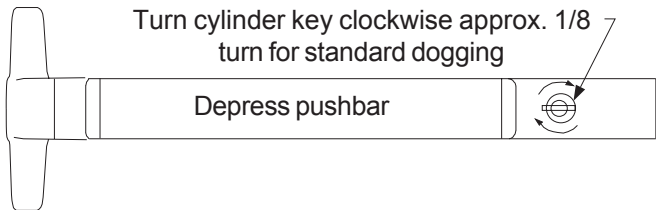

SS WIRING

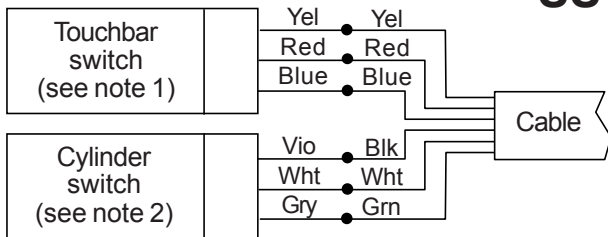

- NOTES:**
1. The touchbar switch is actuated whenever the touchbar is depressed or the device latch bolt is retracted. This switch may be used for initiating an alarm.
 2. The cylinder switch is actuated when the key is inserted into the lock cylinder and turned clockwise. This switch may be used for shunting or resetting an alarm.
 3. A continuous current electric hinge or equivalent is required to transfer the wiring from the door to the frame.
 4. Splice electric hinge wires and cable wires together with wire nuts. Unused wires should be cut off or insulated.
 5. Cut device to proper length before connecting cable and switch wires.

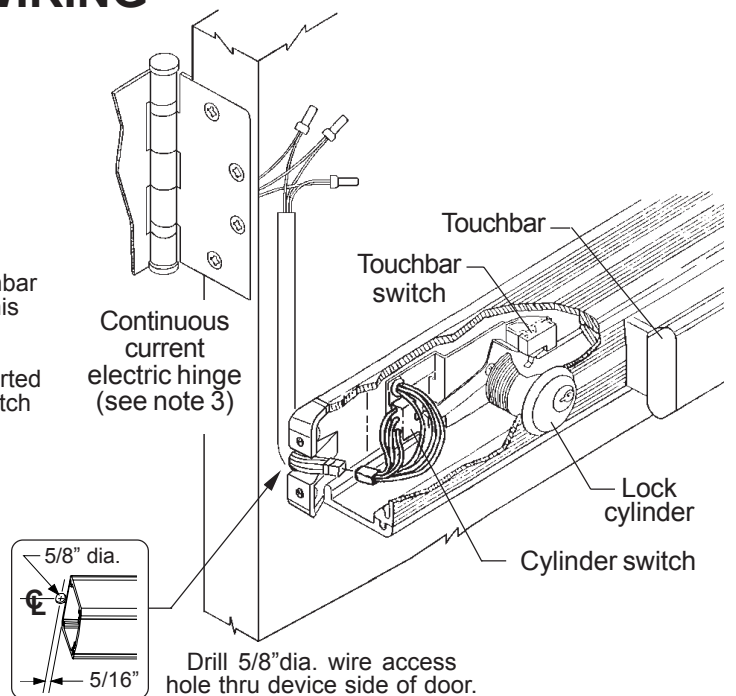

OPTIONAL EQUIPMENT - CONTINUED

EL WIRING

12 AWG, 200' maximum or
14 AWG, 100' maximum

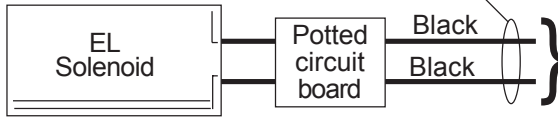

ELECTRICAL SPECIFICATIONS

Voltage: 24 VDC
Current: 16 A inrush (0.3 sec.)
0.25 A holding

Solenoid must be wired to a PS873 logic board:



If 871-2 logic board, refer to Von Duprin instructions 941352.



If other 873 logic board, refer to Von Duprin instructions 941356.

NOTE

When power is applied to the **potted circuit board**, the solenoid receives a momentary signal to retract and a separate signal to hold as long as power is applied. When attempting to retract solenoid again, power must be removed from the circuit and reapplied.

Troubleshooting solenoid operation

If the solenoid fails to retract the latch bolt when power is applied, recheck wiring for proper connections.

If solenoid retracts latch bolt momentarily but will not remain in energized position:

1. Check wiring for proper connections, gauge, and distances.
2. Check for latch bolt binding caused by improper strike installation, warped door, etc.

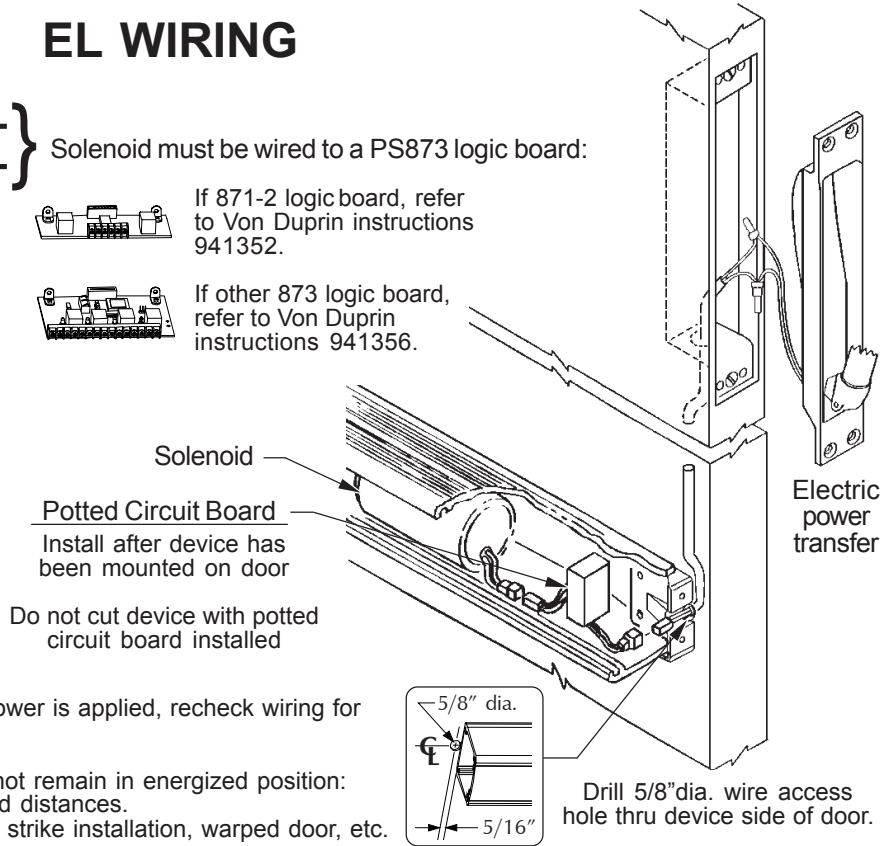

Do not cut device with potted circuit board installed

EL ADJUSTMENT PROCEDURE

- A. Check for proper function:**
1. Make sure device is not dogged.
 2. Depress pushbar and make sure latch bolts retract and extends fully (see Figure 3).
 3. Electrically energize solenoid and hold.
 4. Check latch bolt(s) for full retraction (must clear strike (see Figure 3).
 5. Release solenoid and check latch bolt extension (see Figure 3).
 6. Continue to Section B if device does not function electrically.
- B. Determine if dogging rod adjustment is too long or short:**
1. The dogging rod adjustment is too **long** if latch bolt does not retract and clear strike (see Section C for adjustment).
 2. The dogging rod adjustment is too **short** if latch bolt does not fully extend **or** latch bolt fully retracts but solenoid releases while energized (see Section D for adjustment).
- C. Adjust solenoid if dogging rod is too long (see Figure 4):**
1. Remove end cap ① and dogging cover ②.
 2. Loosen cap screw ③.
 3. Hold plunger ⑤ depressed in solenoid housing ⑥.
Note: Push hard against plunger ⑤ to overcome an internal spring in solenoid housing ⑥.
 4. Turned threaded bushing ④ in to shorten dogging rod ⑦ so latch bolt fully retracts.
 5. Tighten cap screw ③.
Note: Cap screw ③ must be tightened against flat on threaded bushing ④. Apply a few drops of Loc-Tite 222 to threads of cap screw ③.
 6. Replace dogging cover ② and end cap ①.
 7. Return to Section A to check for proper function.

Latch bolt extended

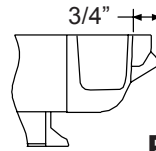

Latch bolt retracted

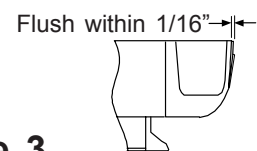

Figure 3

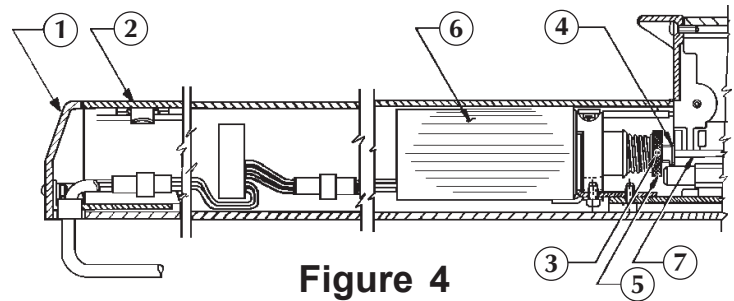
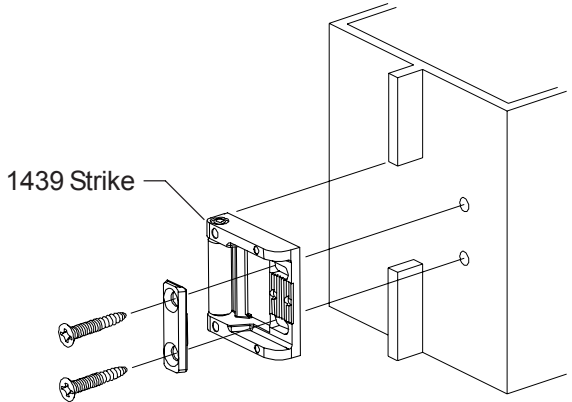

Figure 4

- D. Solenoid adjustment if dogging rod adjustment is too short (see Figure 4):**
1. Remove end cap ① and dogging cover ②.
 2. Loosen cap screw ③.
 3. Hold plunger ⑤ depressed in solenoid housing ⑥.
 4. Turn threaded bushing ④ out to lengthen dogging rod ⑦ so plunger ⑤ just bottoms in solenoid housing ⑥ and latch bolt is fully retracted.
Note: Push hard against plunger ⑤ to overcome an internal spring in solenoid housing ⑥.
 5. Tighten cap screw ③.
Note: Cap screw ③ must be tightened against flat on threaded bushing ④. Apply a few drops of Loc-Tite 222 to threads of cap screw ③.
 6. Replace dogging cover ② and end cap ①.
 7. Return to Section A to check for proper function.

This page is intentionally left blank



1439 Strike Frame Preparation

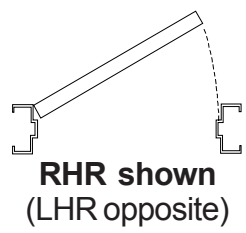

RHR shown
(LHR opposite)

Metal	#25 Drill #10-24 tap
Wood	1/8" Drill pilot 1" deep

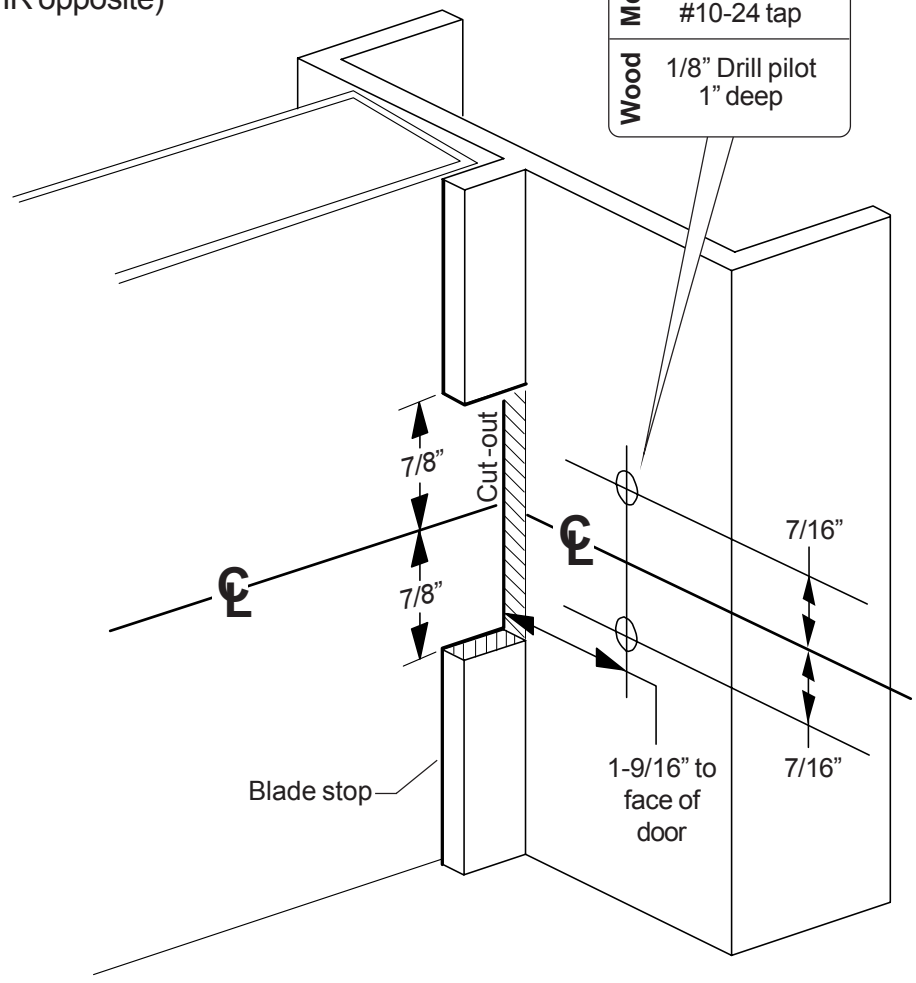

299 Strike Template

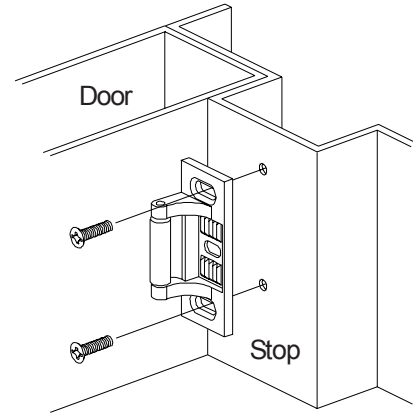

Cut paper along this line and place on door stop against edge of door (see picture below)

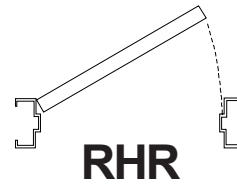

Metal	#25 Drill #10-24 tap
Wood	1/8" Drill pilot 1" deep

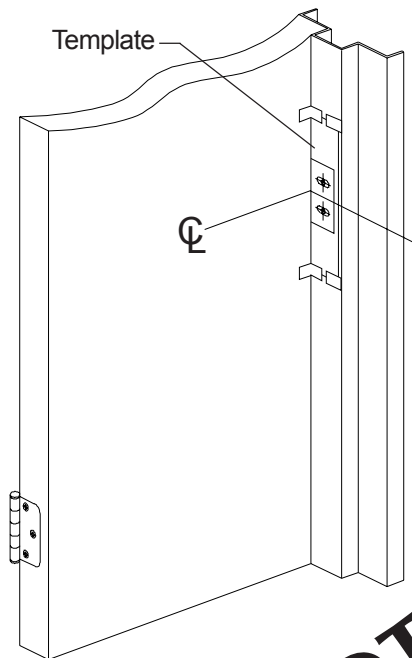

Door edge

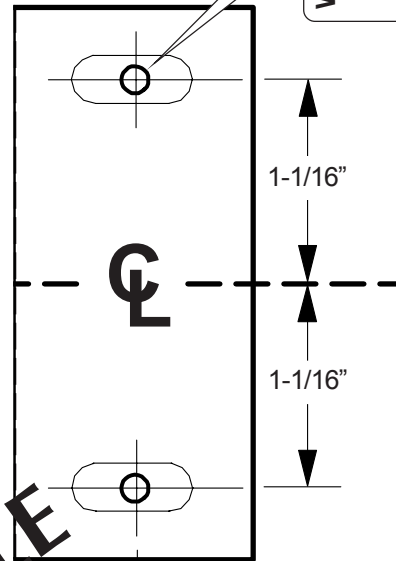

DO NOT SCALE

